

# ***4 Advanced Operations: Process-Control***

## **Purpose**

This chapter explains how to establish operating parameters to optimize the performance of your MART Power Washer. Use information about the following to help get the best cleaning results and optimize energy usage, while minimizing chemical usage and problems:

- Managing chemical concentration
- Setting rinse cycle time (optional ARC)
- Setting the 7-day dual-circuit clock
- Monitoring assemblies and parts

## **Prerequisites**

Before you read this chapter, we recommend that you read the following thoroughly:

- *"Important Safety Instructions and Warnings"* (in the front material)
- Chapter 1, *"Overview"*
- Chapter 3, *"Basic Operations"*

## Safety/Precautions

Before you operate the washer, read and follow these recommended safety/precaution instructions:

***WARNING! Never get inside the washer cabinet when the main power supply is ON. This could result in severe injury or death.***

## What You Will Learn In This Chapter

In this chapter you will learn the following about establishing operating parameters:

- Chemical-concentration management
- Temperature adjustment
- Rinse-system control (optional ARC)
- Setting the 7-day clock
- Steam-exhaust timer
- Monitoring

# 1. *Chemical-Concentration Management*

This section discusses the following topics:

- Chemical: General
  - Selecting the right chemical
  - Selecting the right concentration
  - Maintaining the proper chemical charge
  - Problems
    - Foaming related to chemical concentration
    - Supersaturation of solution
  - Charging the power washer with chemical
- 

## 1.1. Chemical: General

Your MART Power Washer uses an aqueous (water-based) alkaline cleaner, not a solvent. When charged with a *light* concentration of cleaner, the washer will give you excellent cleaning results. Generally, *light* means a 2-5% concentration by volume of any high quality non-foaming chemical compound.

Good chemical management should be done on a daily basis. Check the concentration of the cleaning solution and adjust it as necessary -- this is important not only for cleaning results, but it will also reduce cleaning time and other chemical-related problems such as foaming.

You must also use some chemical during the cleaning cycle in order to prevent corrosion (rusting) damage to the washer itself.

Most chemicals provide adequate corrosion prevention at low concentrations, but some do not. Generally, to prevent corrosion the pH of the solution must be above 10.5. Your MART Service Tech. can discuss with you in more detail the pH requirements, and which chemicals may cause corrosion. If you do not know what your solution pH is, you must monitor it to verify that it is kept above 10.5.

MART Power Washers are aqueous based cleaning systems. They are designed and manufactured to work with wash solutions that are of the same specific gravity and viscosity as water. Chemicals or additives, which alter the specific gravity or viscosity of the wash solution, will change the overall performance of the system. Use only chemicals that are designed for use in aqueous systems.

## 1.2. *Selecting the Right Chemical*

When you select a chemical, *first* determine the compound best suited for the type of metal or part. *Second*, take into account the type of soils to be removed.

Use the following guidelines in selecting the right chemical:

**Type of Metal** for **ferrous metals**, such as cast iron or steel, select a caustic compound containing sodium hydroxide or potassium hydroxide.

For **non-ferrous metals**, such as aluminum, select compounds specifically designed to wash parts without destroying them. Such compounds contain, for example, sodium metasilicate, trisodium phosphate, and sodium bicarbonate. The compound may also contain a small percentage of inhibited caustic, to make it more aggressive, without damaging the metals.

**WARNING!** *Exposing aluminum to a high concentration of caustic chemical, such as sodium hydroxide or potassium hydroxide, will blacken the surface of the parts being cleaned, and, if exposed for five minutes or more, can etch the surface.*

**Type of Soils** A wide of range of compounds is available to remove soils. Each compound reacts differently with the soils -- some are more aggressive than others at "popping" certain soils from part surfaces. However, no compound removes all types of soils equally well.

To select a chemical, decide which soils you most want removed.

For further details on various chemical compounds and their suitability for your application, call your MART Service Tech to discuss your requirements, or contact your chemical supplier.

**WARNING!** *The selected chemical must prevent corrosion to the steel parts in your washer. Generally, a solution pH above 10.5 is required. Do not use chemicals that cause corrosion, or that cause a solution pH below 10.5.*

**WARNING!** *The selected chemical must be non-foaming.*

## 1.3. *Selecting the Right Concentration*

The MART Power Washer is a high-pressure, high-temperature cleaning system that uses a balance of the following factors to achieve cleaning results:

$$\text{Power} \times \text{Temperature} \times \text{Chemical} \times \text{Time} = \text{Clean}$$

Because the *exact* combination of these factors depends on your shop's cleaning standards and operating requirements, specific chemical concentration recommendations are not possible. Below are formulas for calculating the amount of chemical needed to charge a reservoir of water for cleaning. To use these you will need to know the volume of your washer's reservoir and the recommended initial chemical concentration. Select the formula to use based on whether your chemical is powder or liquid.

For Powder:

$$\frac{\text{Reservoir Size (gal)} \times \text{Recommended Concentration (oz/gal)}}{\text{Divided by 16 oz. / lb.}} = \text{lbs. of Chemical to add.}$$

For Liquid:

$$\frac{\text{Reservoir Size (gal)} \times \text{Recommended Concentration (oz/gal)}}{\text{Divided by 128 fluid ozs. / Gal}} = \text{gals. of Chemical to add.}$$

You must test and adjust the variables in your application to determine an effective chemical type and concentration.

Chemical concentration depends on:

- Your cleaning standards
- Type of metal or material being cleaned
- Shape of parts
- Type of soils to be removed
- Rate of speed required in cleaning
- Operating temperature of the washer
- Water hardness

Every chemical compound has an optimal operating temperature range. Generally, chemical is more aggressive at higher temperatures. As a general rule, for every 10° F (6° C) rise in temperature, a chemical reaction doubles in speed.

The MART Chemical Group offers a complete range of chemicals for use in MART Power Washers. They can help you select the proper chemical from our Power Kleen line and recommend an appropriate initial chemical concentration.

If you are using your own chemicals contact your chemical supplier for details -- and adjust your MART Power Washer's chemical concentration accordingly.

## 1.4. Maintaining the Proper Chemical Charge

After you have developed an effective chemical concentration, as described in the previous section, you must monitor and maintain it for optimal cleaning results and washer performance.

Initially, you could start by monitoring chemical concentration weekly (or, every 40 hours of washer operation). However, you should develop a monitoring schedule based on the frequency of washer operation, degree of cleanliness required, the types of soils to be removed from parts, and so on. Your monitoring schedule should account for all the variables in your application in order to give you the best cleaning results, while using the least amount of chemical possible.

For help in developing a chemical-concentration-monitoring schedule, call your MART representative to discuss your application(s) and requirements, or contact your chemical supplier.

There are two fast and accurate monitoring methods:

### 1. Titration Test

Perform this test to determine the concentration of chemical by titrating the alkalinity of the solution with an indicator and a drop count.

The results determine the number of ounces of chemical to add per gallon of water-capacity.

Refer to chapter "*Maintenance*" for procedural information.

### 2. Conductivity Test

Conductivity testing equipment is optionally available from MART. Refer to chapter "*Options*" if you have purchased a conductivity controller and probe equipment for your washer.

## 1.5. Problems

There are two principal problems related to managing chemical concentration:

- Foaming
- Supersaturation of solution

For related information, refer to chapters "*Maintenance*" and "*Troubleshooting*."

### 1.5.1. Foaming Related to Chemical Concentration

Foaming can occur for these reasons:

- Chemical compound
- Type of soils being removed
- Improper solution temperature

#### Chemical

the de-foaming component in a chemical compound represents only a small percentage of the total compound. And, de-foaming component percentages vary from compound to compound. Since the washer requires only a light chemical charge, you may need to add a "*booster charge*" of *de-foamer*, if foaming is a problem.

Consider adding a defoaming agent rather than more chemical, given the following conditions:

- Your cleaning needs are being met.
- You have determined that the type and amount of chemical are appropriate for the soils being removed.
- You have determined that the washer's operating temperature is appropriate for the type of soils, and the type and amount of chemical.

#### Soils

The type(s) of soils can react adversely with the chemical during cleaning to cause a foaming problem. Select a chemical that is appropriate for the soils to be removed. It is also a good idea to check with your MART representative or your chemical supplier to be sure that the type and amount of chemical are appropriate for the following:

- Type of metal
- Makeup of part(s)
- Operating temperature of the washer

**Temperature** Test and adjust the washer's operating temperature to determine what is optimal for your chemical. Remember that altitude, water hardness, and types of soils can also affect the temperature-and-chemical reaction. Refer to section "*Temperature Adjustment*" in this chapter.

If you need to discuss your application(s) and requirements, call your MART representative or contact your chemical supplier.

### 1.5.2. Supersaturation of Solution

The MART Power Washer is a closed-loop cleaning system. It re-uses the cleaning solution without discharging it for treatment or disposal.

When the cleaning solution is fully saturated with greases and oils, merely adding more chemical will not improve cleaning results -- the volume of emulsified greases and oils is greater than the grease to be removed and has no where to go. This condition is called *supersaturation of solution*.

To correct this problem, you must remove *greases and oils* from the solution. Allow solution to cool and oils to rise to surface, then:

- Manually skim greases and oils from the front reservoir; change the solution.
- Or -
- Run the optional **Oil Skimmer** device. If you have purchased one from MART, refer to chapter "*Options*" in this manual.

As part of the sludge clean-out procedure, you will clean out/re-charge the power washer with chemical. Refer to chapter "*Maintenance*" for the sludge clean-out procedure.

## 1.6. Charging the Power Washer with Chemical

Refer to chapter "*Installation*," section "*Startup Procedure, Chemical-Charging*" for instructions.

## 1.7 Corrosion Protection

Since alkaline cleaners are non-corrosive to ferrous metals the cost to manufacture cleaning equipment can be reduced. Stainless steel is not required for construction and protection of the reservoirs, pumps, tanks, cabinets and turntables. In fact carbon steel can be used for the reservoirs and cabinets with no detrimental effects as long as the concentration of alkalinity is maintained. With proper maintenance of your chemical



concentration the carbon steel components are well protected and will provide years of service. Carbon steel MART power Washers are still in service that are 20+ years old.

***Many chemicals provide adequate corrosion prevention at low concentrations, but some do not. Generally, to prevent corrosion in carbon steel the pH of the solution must be above 10.5.***

MART Power Washers are aqueous based cleaning systems. They are designed and manufactured to work with wash solutions that have the same the specific gravity and viscosity as water. Chemicals or additives, which alter the specific gravity or viscosity of the wash solution, will change the overall performance of the system. Use only MART Power Kleen chemicals or other chemicals that are designed for use in aqueous systems.

Below is a short introduction to the complete chemical line offered by the MART Corporation Chemical Group.

## 1.8 MART Chemical Group

MART Power Kleen detergents and additives are specially formulated for use in all MART Power Washers. Power Kleen products cover a wide range of applications and most likely there is a Power Kleen product specifically designed for your particular cleaning applications. In all cases Power Kleen products provide the highest degree of efficient, effective cleaning.

Power Kleen products are highly effective at controlling foaming and are labeled "Controlled Foam" products. Additional defoamer products are available to help in difficult foaming situations.

Power Kleen products remain effective longer than many other detergents used in cabinet washer applications and, in many instances, less Power Kleen detergent is required for a given application. Power Kleen chemicals have 100% concentrated active ingredients. The reason MART compounds remain active longer is that they contain NO fillers. Other chemical suppliers may "fill" or bulk up their chemistries with non-active ingredients that do nothing except fill up the chemical drum. These fillers end up as sludge in the bottom of the Power Washer and must be disposed of, thus adding to the disposal costs. Since MART Power Kleen is fully active chemistry 100% of the chemical goes to work cleaning your parts. As a result, your cleaning dollar goes further and your disposal costs are less.

## 1.9 Recommended Chemicals

### **Power Kleen I – Iron and Steel**

Fast acting, long lasting Power Washer detergent for removing heavy oils and grease, many types of carbon, and other deposits from all ferrous metals.

### **Power Kleen II – Aluminum Safe**

Multi-Metal, biodegradable Power Washer detergent for removing oil, grease and dirt from both ferrous and non-ferrous materials.

**Power Kleen IIIP – Electric Safe**

Powdered Power Washer detergent for removing oil, grease and dirt from electric motors, generators, etc. Rinses completely with no conductive residue.

**Power Kleen III L – Electric High-rinse**

Liquid Power Washer detergent for removing oil, grease, and dirt from electric motors, generators, etc. Highest rinsability factor with no conductive residue.

**Power Kleen IV – Aerospace**

Specially formulated Power Washer detergent for removing carbon, grease, and dirt from Aerospace Metals, Aircraft Parts, and chemically sensitive space age metals.

The MART Corporation web site [www.martwash.com](http://www.martwash.com) is a vast information base for cleaning chemistry and has complete information for the entire Power Kleen line of chemicals. At the site you may download MSDS sheets for each product and find more in depth application data for each product. Optionally, you may call MART Chemical Sales and Technical Services staff who are trained to help customers select the most appropriate product for their specific cleaning applications and answer questions regarding chemical use and application.

## 2. Temperature Adjustment

The recommended maximum temperature operating points are shown in the following figure. **NOTE:** The set point on the controller can differ from the actual temperature.

Maximum Actual Operating Temperature	
<u>Altitude in Feet</u>	<u>Temperature ° F</u>
0 - 2000	190° F ((88° C)
2000 4000	185° F (85° C)
4000 5000	180° F (82° C)
5000 and above	call MART

**WARNING!** Do NOT exceed recommended settings, or serious damage can occur to the wash pump (cavitation).

**Fig. 4 - 1: Maximum Actual Operating Temperature**

The temperature controller is located inside the electrical control panel. Refer to the following figure.

**WARNING!** Disconnect power before opening the control panel.

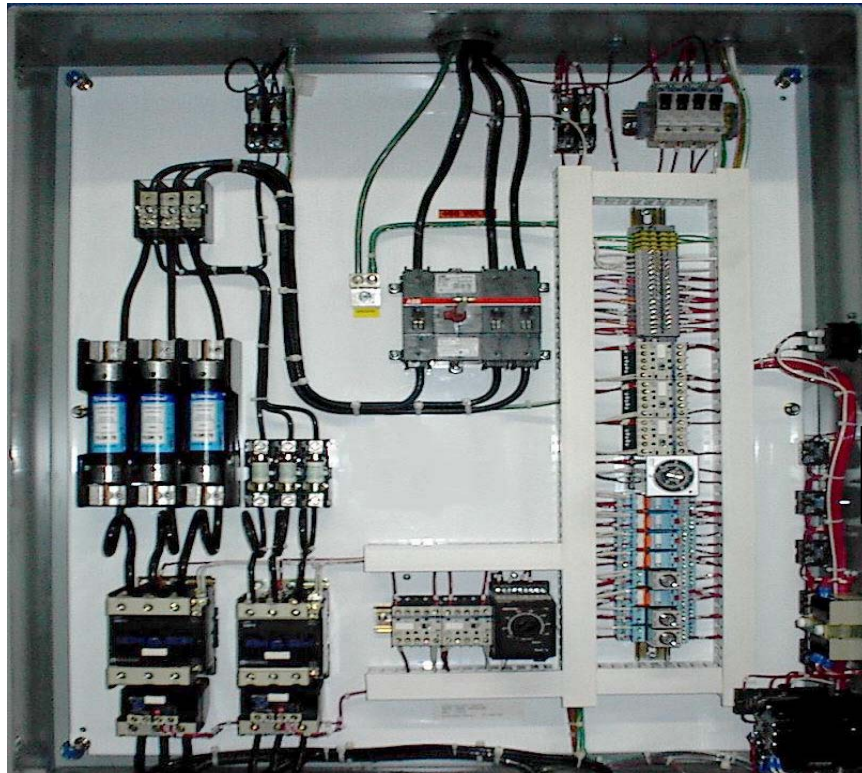

**Fig. 4 - 2: General Layout of the Electrical Control Panel (Block Diagram)**

Since temperature is only one of the variables that affect cleaning results, no general rule can be given for the temperature setting. You must test and adjust temperature, as well as other variables, to determine the optimum. Start with the recommendation of your MART Service Tech or your chemical supplier.

**Guidelines:**

As temperature increases, greases and oil become more fluid. Since grease is the primary binder that holds and contains the soils on the parts, heat melts the binder generally producing better cleaning results. *Do not exceed recommended temperatures shown in Fig. 4-1, however, or the main wash pump may sustain severe damage due to cavitation.*

Use the following table as a guide in testing and adjusting temperature:

<b><u>Temperature</u></b>	<b><u>Type of Soil</u></b>
140-160 °F (60-71° C)	Light oils
160-175°F (71-79° C)	Greases
175°F + (+79° C)	Carbon, Paint

**NOTE:**

- Higher temperatures use more energy.
- Higher temperatures will allow a longer rinse cycle, due to greater evaporation.

### 3. Rinse-System Control (optional ARC)

The Automatic Rinse System (ARC) is a fresh-water rinsing system. It is powered by waterline pressure. It allows the operator to control rinse characteristics and the application of a rust inhibitor by means of the chemical injector pump.

The following controls rinse time:

- Amount of makeup water needed, due to water loss through evaporation or drag-out.
- Automatic rinse system (ARC) timer

*In controlling rinse cycle time, water loss takes priority.* The amount of makeup water required determines the maximum rinse time allowed, if any.

Set rinse cycle duration by adjusting the automatic rinse cycle (ARC) timer, located in the electrical control panel. Refer to Fig. 4-2.

**WARNING! Disconnect power before opening the control panel to make adjustments.**

#### 3.1. Setting the Rinse Timer

The rinse timer is an adjustable timer with a range of 0-10 minutes.

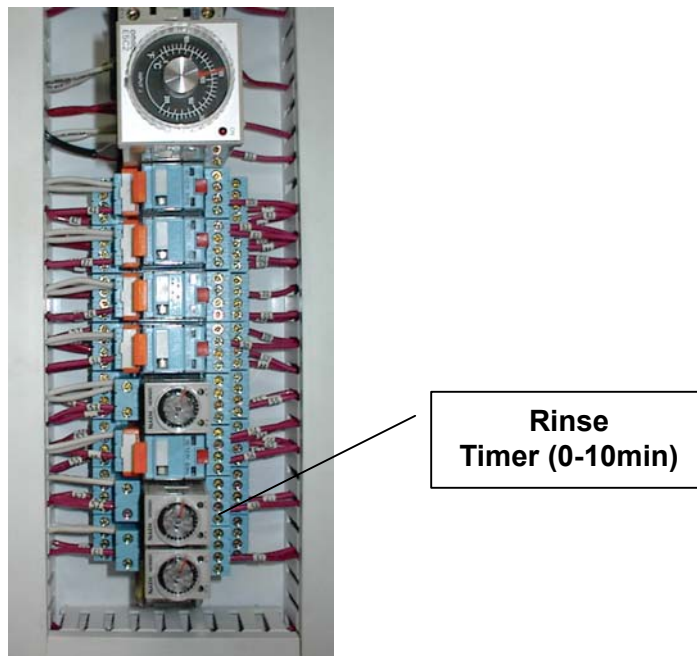

**Fig. 4 - 3: Automatic Rinse Cycle (ARC) Timer Increments**

If you find that your rinse is not long enough, consider operating at a higher temperature in order to evaporate more water during the wash cycle. Also, be sure that the auto steam exhaust (ASE) is removing steam -- moving up to the next ASE motor size may be an answer.

## 3.2. Rinse Injector Pump

The chemical injector pump allows adjustment of the flow rate of chemical injected into the rinse water. It delivers liquid additive at very precise dosage rates (per minute). The regulator and gauge allow the operator to adjust the rinse spray characteristics of flow and pressure.

Contact your chemical supplier for the appropriate inhibitor chemical, and for instructions on using it.

**NOTE:** Monitor inhibitor-chemical usage visually. Replace drums as needed to ensure that inhibitor chemical is applied with each rinse.

Before you operate the rinse system, you need to make the two following adjustments.

**To adjust the chemical concentration in the rinse water (chemical injector pump), follow this procedure:**

1. Determine the number of nozzles your washer has for its rinse system (in order to use the correct graph to achieve the desired rinse-regulator pressure). Your washer will have 3, 4, or 5 rinse nozzles.
2. Select the proper graph. (Refer to the following figures in this section.)

**NOTE:** The graphs are for a 1.06 gal/hr (4 l/hr) injector pump, MART #50107; and 50° .053-inch (1.3 mm)-diameter-orifice nozzles, MART #29010.

3. Determine the rinse-regulator pressure your washer currently uses in the rinse cycle.

**NOTE:** MART sets the washer's rinse-regulator pressure to 30 PSI (208 kilopascals) at the factory. However, your washer's pressure may differ, depending on the incoming water-supply pressure.

4. Change the pressure, if you wish.
5. Determine the chemical mix ratio, *in ounces per gallon (oz./gal.)*, that you require for the rinse solution concentration.
6. On the graph you have selected, find the correct *Mix Ratio (OZ/GAL)* on the horizontal axis.
7. Based on the rinse-regulator pressure you selected for your washer's rinse operations, find the correct rinse-regulator pressure *line on the graph*.

**NOTE:** There are five rinse-regulator pressures represented on each graph. Refer to the "key-code" box under the graph to select the correct line, based on your rinse-regulator pressure.

8. Trace a straight line from the *Mix Ratio (OZ/GAL) point on the horizontal axis* up to a point on the correct pressure line.
9. From the *point on the pressure line*, trace a straight line left over to a point on the vertical axis. The point on the vertical axis represents the percent of full output at which you should set the rinse injector pump to achieve the required mix ratio.
10. Find the injector pump's control knob.
11. Set this knob to the percent of full output.

**NOTE:** The control knob is divided into 12 segments. Each division represents 8.33% of full output.

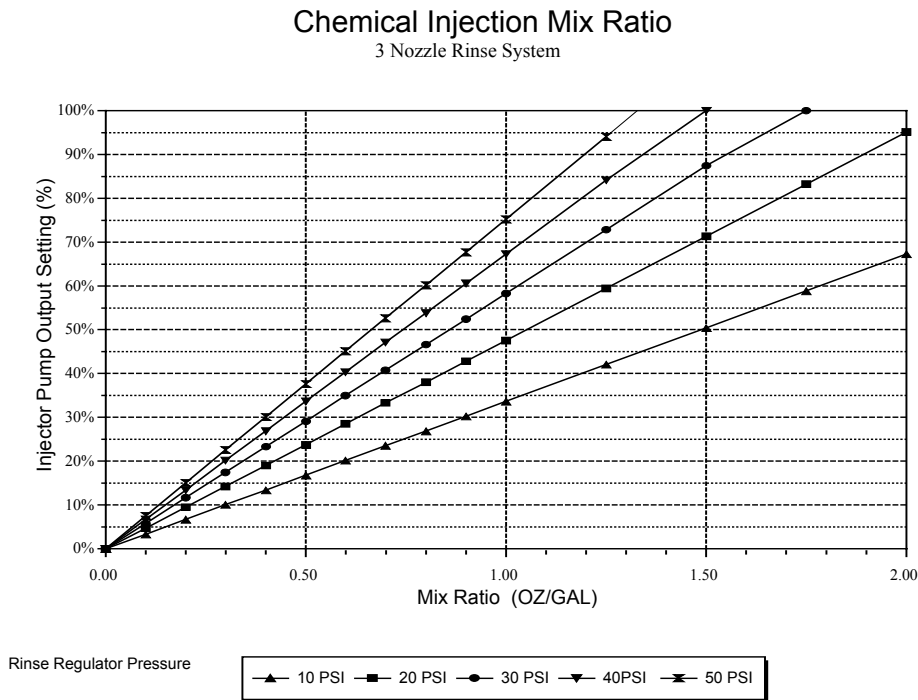

**Fig. 4 - 4: Injector Pump Output Setting: 3-Nozzle Rinse System**

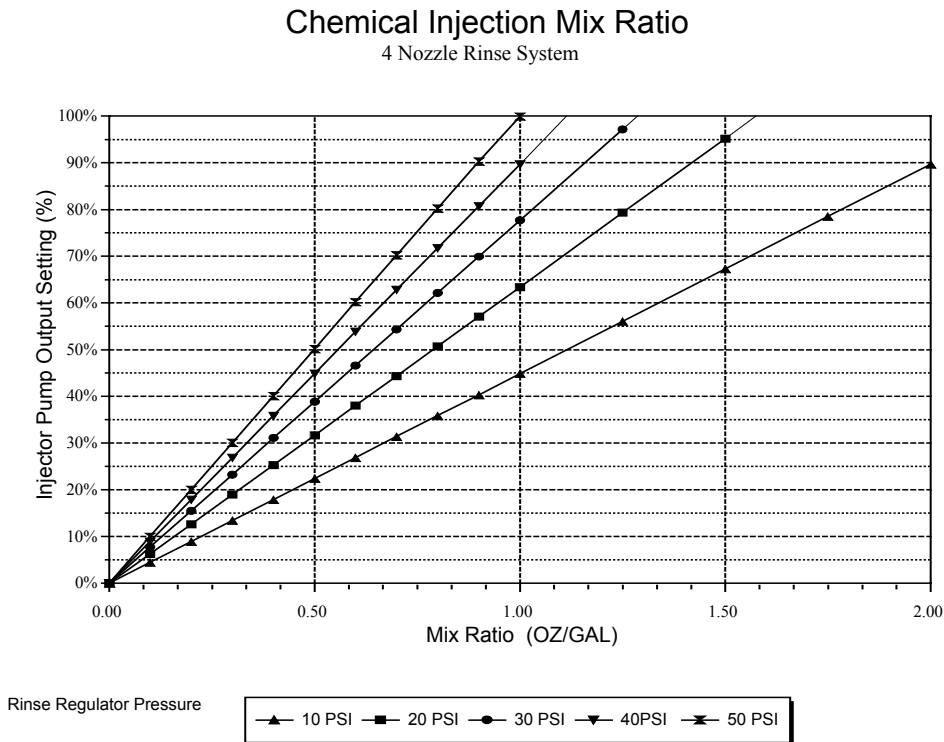

**Fig. 4 - 5: Injector Pump Output Setting: 4-Nozzle Rinse System**



### Chemical Injection Mix Ratio 5 Nozzle Rinse System

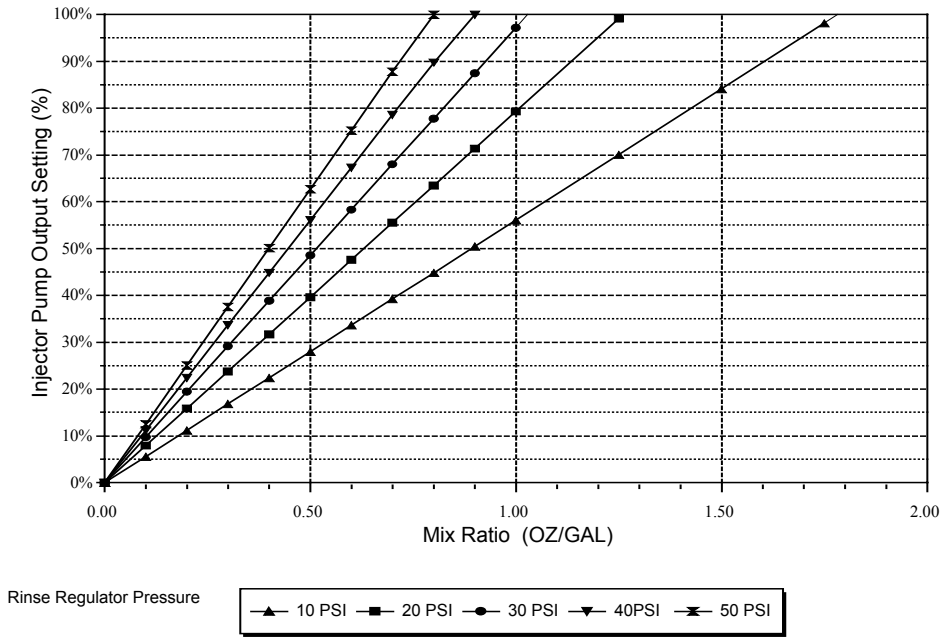

**Fig. 4 - 6: Injector Pump Output Setting: 5-Nozzle Rinse System**

### 3.3 Rinse Water-Flow Adjustment

To operate the water regulator, *follow these guidelines:*

**NOTE:** The regulator is factory pre-set. Adjust it to achieve rinse characteristics that meet your requirements.

#### To Get This:

Smaller drops, more volume →  
Larger drops, less volume →

#### Adjust the Regulator for:

Higher gauge reading  
Lower gauge reading

Generally, medium settings (30-35 PSI [208 - 242 kilopascals]) give the best results.

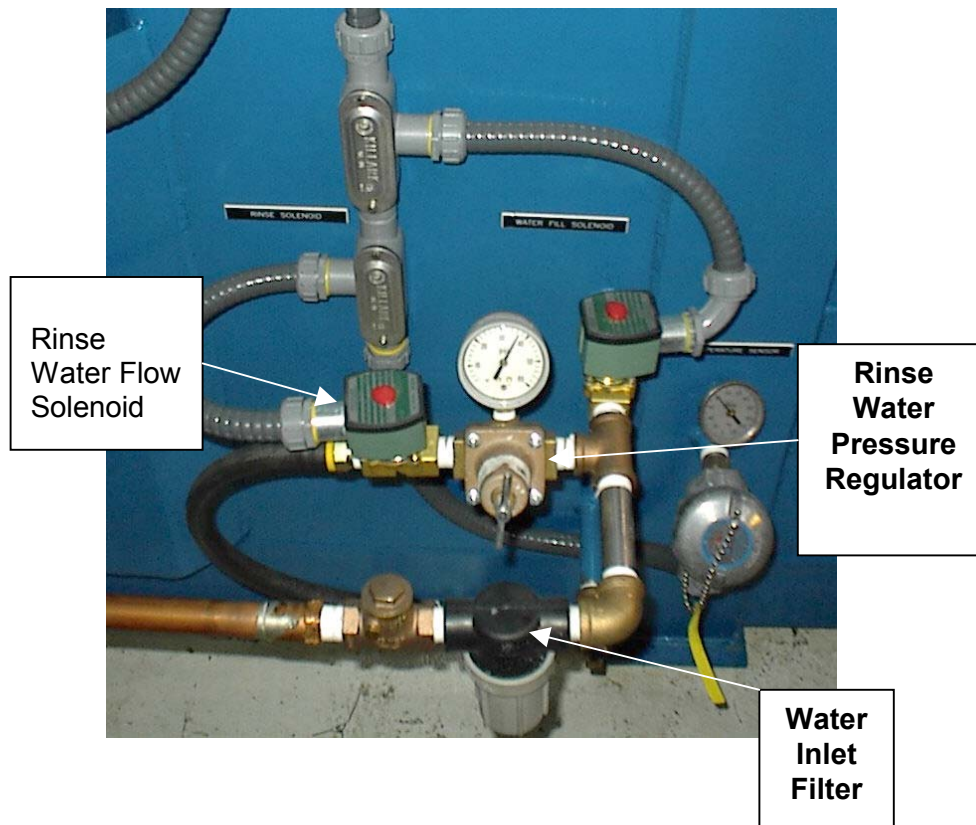

**Fig. 4 - 7: Rinse water flow adjustment**

## 4. Setting the 7-Day Dual-Circuit Clock

The 7-day clock is a programmable digital dual-circuit clock that allows you to pre-set the days of the week and the time of day for the washer to:

- Heat up/water-fill
- Remain in "shut-down" (*off*) mode
- Program "run" times for optional devices

The clock is located on the face of the electrical control panel, as shown in the following figure. **Circuit #1** controls the heating and water-fill times. **Circuit #2** controls the "auto" runtime for optional devices such as the Clean Machine and the Oil Skimmer.

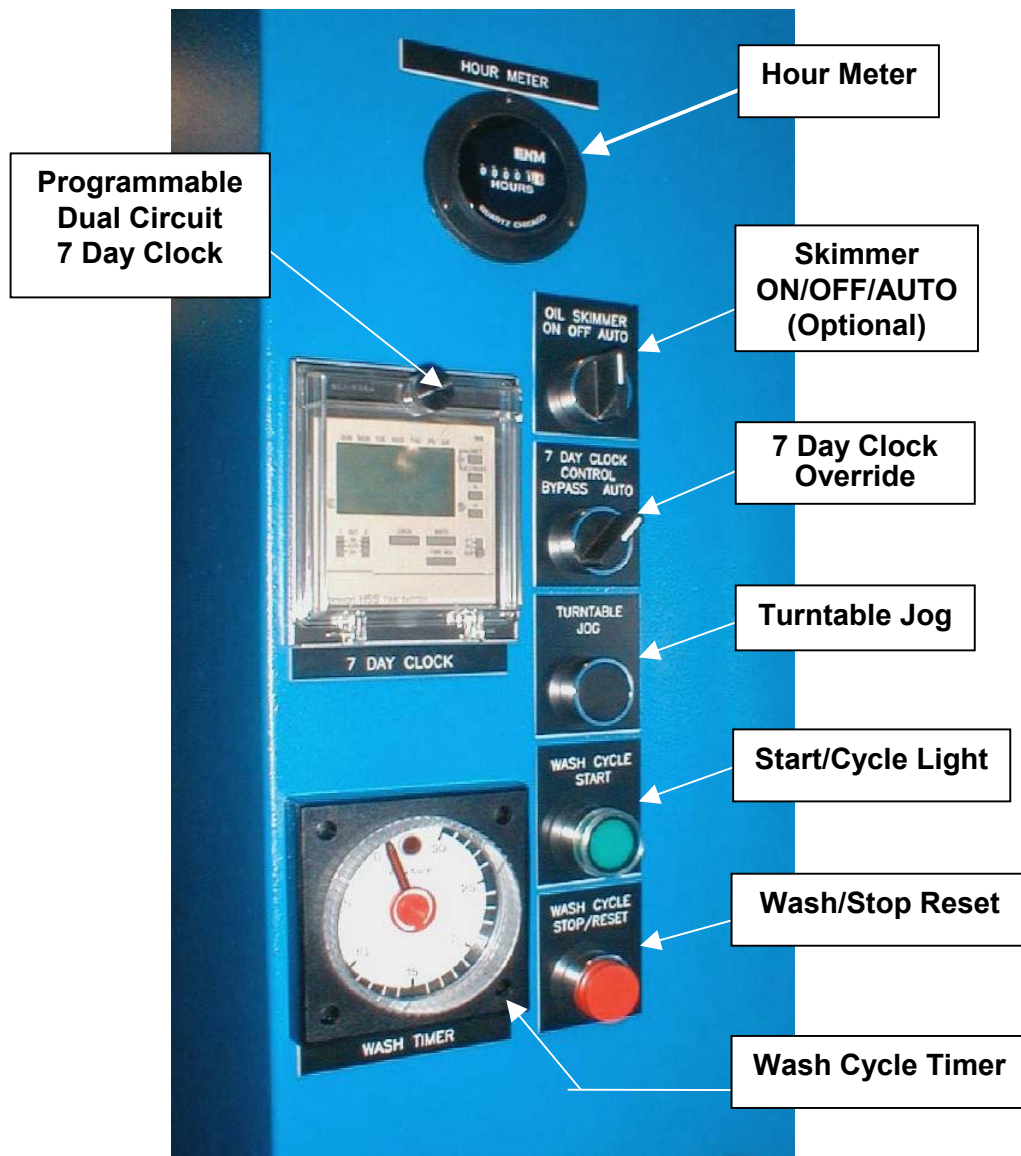

Fig. 4 - 8: Standard Turntable Power Washer Control Panel

Refer to your vendor-provided manual bound into the back of this manual for instructions on setting the clock.

**CAUTION!** *If the main power supply is OFF for a time period that exceeds the power-outage carry-over specified in the vendor-supplied 7-day dual-circuit clock manual, be sure to reset the 7-day dual-circuit clock.*

## 4.1. 7-Day Dual-Circuit Clock and Optional Devices

A separate manual/off/auto switch controls some optional devices, such as the Clean Machine and the Oil Skimmer, and circuit #2 of the 7-day dual-circuit clock, located on the face of the electrical control panel.

**In order for these devices to work in "automatic mode," follow this procedure:**

1. Program the 7-day clock's circuit #2 for the operating runtime (day of week, start time, and stop time).
2. Set the device's *manual/off/auto* switch to *auto*.

**NOTE:** *If you omit step #1, devices that are controlled by a manual/off/auto switch will not work when you set the switch to auto. (You can, however, run such devices manually by setting the switch to manual.)*

For more information on operating options that you have purchased from MART, refer to chapter "Options."

## 5. Steam-Exhaust Timer

The steam-exhaust timer controls the length of time that the automatic steam exhaust (ASE) operates after the end of the wash or rinse cycle. The timer is located inside the electrical control panel. Refer to Fig. 4-2.

How the ASE cycle actually works depends on your washer's configuration:

**ARC (optional)** If your washer is equipped with the optional automatic rinse cycle (ARC) the automatic steam exhaust (ASE) cycle removes steam from the washer cabinet:

- During the wash cycle
- During the optional automatic rinse cycle (ARC)
- For the ASE timer-set period of time *after* the automatic rinse cycle (ARC) cycle has completed

**No ARC**

If your washer is *not* equipped with the optional automatic rinse cycle (ARC), the automatic steam exhaust (ASE) cycle removes steam from the washer cabinet:

- For the ASE timer-set period of time *after* the wash cycle has completed

### 5.1. Setting the ASE Timer

The steam exhaust timer is an adjustable 0-10 minute timer.

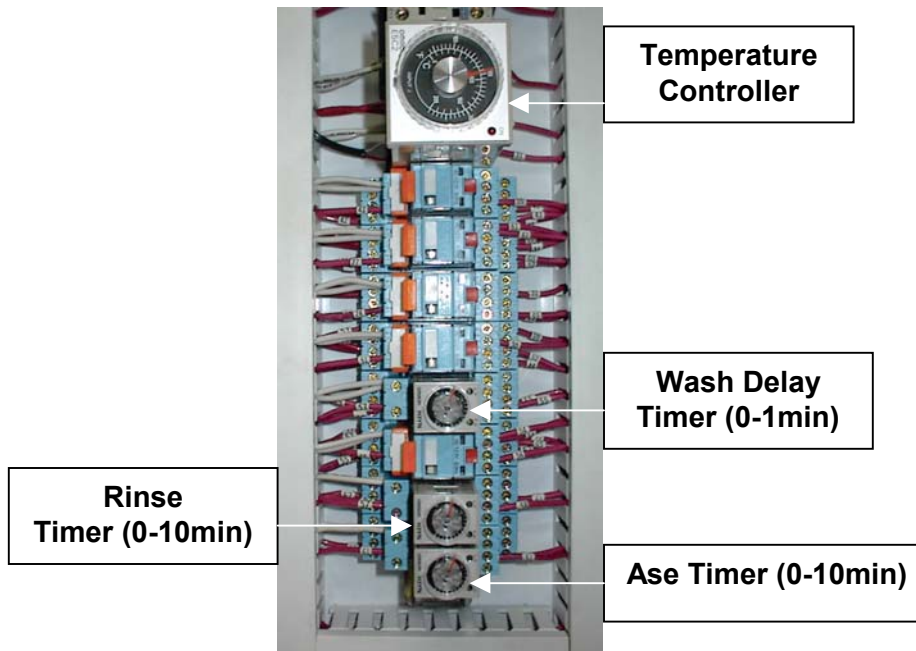

Fig. 4 - 9: Automatic Steam Exhaust (ASE) Cycle Timer Increments

Many factors affect optimal run-time for the ASE cycle. For example:

- Operating temperature of the power washer
- Atmospheric pressure
- Feet above sea level at the installation site

**To test for the most effective ASE cycle, follow this procedure:**

1. Start by setting the ASE timer to 5 minutes.
2. Run the ASE cycle.
3. Check to see if any steam remains in the cabinet after the ASE cycle has completed.
4. Increase or decrease the ASE timer by one-minute increments. (Generally, if steam remains in the cabinet, increase the timer by one minute.)
5. Repeat steps #2 - #4 until the cabinet is purged of steam.

***WARNING! When you run this test, do not open the washer cabinet door until the automatic steam exhaust (ASE) cycle has completed. Steam can contain chemical used in the wash cycle. Refer to your chemical supplier's warnings about the chemical you use.***

***NOTE:*** When the *start* button light goes out, the ASE cycle has finished.

## 6. Monitoring

You must set up a monitoring schedule for washer assemblies and parts. Start with the following:

- Lubrication
- Sludge build-up
- Intake filter
- Amp draw & nozzle wear

Use the *Service Schedule* on the front of the control-panel door as a guide in establishing a monitoring schedule.

**NOTE:** It is important to keep a monitoring record -- post it on the side of the washer or on the door. Have operators initial the record each day after monitoring, and indicate if any maintenance procedures need to be performed.

Refer to chapter "*Maintenance*" for maintenance procedures.

### 6.1. Monitoring Lubrication

Monitoring lubrication of the following *on a daily basis* is extremely important for reliable washer performance:

- Turntable bearings
- Power blast manifold (PBM) swivel (*joint and upper bearing*)
- General lubrication (bearings, motors, and pumps)

Assemblies and parts need to be greased or oiled based on the hours of operation. Refer to the *Service Schedule* on the front of the control-panel door.

**NOTE:** It is important to keep a lubrication record -- post it on the side of the washer or on the door. Have operators initial the record each day after completing lubrication procedures.

## 6.2. Other Monitoring

In addition to monitoring lubrication, include the following on your initial monitoring schedule:

- Sludge build-up (daily)
- Pump intake filter (daily)
- Amp draw & nozzle wear (monthly)

### General Guidelines:

**Sludge** Monitor daily. Clean out *sludge* when there is about 4 inches (10.16 cm) of it on the bottom of the front reservoir.

**Pump Intake Filter** Monitor daily. Clean the *pump intake filter* every 8 hours of operation to remove sludge and other material plugging it.

**Amp Draw/Nozzles** Monitor the *amp draw at the wash pump* on a *monthly* basis to detect nozzle wear. (Nozzle wear is not always visible.)

Perform maintenance procedures based on the hours of operation. Refer to the *Service Schedule* on the front of the control-panel door.

Refer to chapters "*Maintenance*" and "*Troubleshooting*" for more information.