

5 *Maintenance*

Purpose

This chapter discusses the maintenance of your MART Power Washer. In general, the washer is *not* maintenance-intensive. A few key items, however, need regular, scheduled care: Use the information in this chapter to establish and follow a service schedule.

Good maintenance is essential for cleaning results, and long economical life of the washer.

Prerequisites

Before you read this chapter, we recommend that you read the following thoroughly:

- *"Important Safety Instructions and Warnings"* (in the front material)
- Chapter 1, *"Overview"*
- Chapter 4, *"Advanced Operations: Process-Control"*

Safety/Precautions

Before you perform maintenance on the washer, read and follow these recommended safety/precaution instructions:

WARNING! NEVER get inside the washer cabinet when the main power supply is ON. This could result in severe injury or death.

WARNING! Turn the main power supply OFF before opening the electrical control panel!

WARNING! *Be sure that people performing maintenance are qualified and trained for the task.*

CAUTION! *You must turn the main power supply OFF before performing many maintenance procedures. BE SURE to turn the main power supply back ON after you perform maintenance.*

CAUTION! *If the main power supply is OFF for a time period that exceeds the power-outage carry-over specified in the vendor-supplied 7-day clock manual, be sure to re-set the 7-day clock (located inside the electrical control panel).*

WARNING! *Do NOT OVERLOAD the false floor or other horizontal surfaces. The false floor is intended as a chemical-solution cover ONLY! Horizontal surfaces are NOT designed for walking or standing! Walking on the false floor, tank cover, or other horizontal surfaces could result in serious injury or death.*

What You Will Learn In This Chapter

In this chapter you will learn the following about maintenance:

- Service schedule, based on hours of washer operation
- Performing maintenance and common washer adjustments
- Sludge monitoring and clean-out
 - Heat-exchanger and suction tube (cleaning)
 - Heating elements (cleaning)
- Maintenance of options

1. Service Schedule

Your washer comes with a maintenance *Service Schedule* along with the MART Power Washer Manual located in a white pouch inside of the main electrical-control-panel. The following figure shows part of the schedule, organized by hours of washer operation. Maintenance procedures for items in the schedule follow, and are grouped by washer systems and assemblies. Use the **Hour Meter** on the washer's control panel to schedule maintenance by hours of operation.

Service Schedule		
Frequency	Date	Technician
8 Hours (At the end of every shift)		
Wash Pump Intake Filter (inspect/clean)	_____	_____
(NOT Cyclone 30's and Tornado 40's only)		
Turntable Bearings (grease; Lubriplate 1444)	_____	_____
PBM Swivel Joint (grease; Lubriplate 1444)	_____	_____
Sludge Level (monitor)	_____	_____
40 Hours (Weekly)		
PBM Nozzles (inspect/monitor)	_____	_____
Chemical Concentration (test)	_____	_____
Slip Clutch/Torque Limiter (inspect)	_____	_____
160 Hours (Monthly)		
PBM Swivel (inspect/adjust)	_____	_____
Air Intake - Burner Blower Motor (clean)	_____	_____
Amperage Draw at Wash Pump(s)(measure)	_____	_____
Turntable Drive Bearings (grease; AW2)	_____	_____
Upper Manifold Bearing (grease; AW2)	_____	_____
1100 Hours (6 Months)		
(Cyclone 30's and Tornado 40's only)		
Turntable Bearings (grease; Lubriplate 1444))	_____	_____
Voltage at Power Distribution Block (measure)	_____	_____
Door Bearings (grease; AW2)	_____	_____
Wash Pump and Pump Motor (grease; AW2)	_____	_____
Float Assembly (inspect/clean)	_____	_____
ASE Blower Motor (oil)	_____	_____
Burner Blower Motor (oil)	_____	_____
Water Solenoid Valves (clean or replace)	_____	_____
Wash Pump Couplings (inspect)	_____	_____

Fig. 5 - 1: Service Schedule

2. *Performing Maintenance and Common Washer Adjustments*

This section gives maintenance instructions and common washer adjustments for items listed in Fig. 5-1, except sludge monitoring and clean-out, which is in section 3. Items are grouped by washer systems and assemblies.

2.1. Pumps and Power Blast Manifold (PBM) Assembly

This section describes maintenance procedures for the following:

- Wash pump intake filter (inspect/clean)
- PBM swivel joint (grease; Lubriplate 1444)
- PBM nozzles (inspect/monitor)
- PBM swivel jam nut (inspect/adjust)
- Amperage draw at wash pump (measure)
- Upper manifold bearing (grease; Mobilith AW2)
- Wash pump and pump motor (grease; Mobilith AW2)
- Wash pump couplings (inspect)

2.1.1. Wash Pump Intake Filter (Inspect/Clean)

Follow this procedure (refer to the following figure):

CAUTION! Do not remove the pump intake filter box from the reservoir.

1. Remove the front reservoir cover.
2. Clean the pump intake filter box with a stiff-bristle wire brush. (The filter box is located at the bottom-front-left corner of the reservoir.)
3. Run the brush across the top, back, and right hand-side of the filter box to remove sludge and gasket material.
4. Replace the reservoir cover.

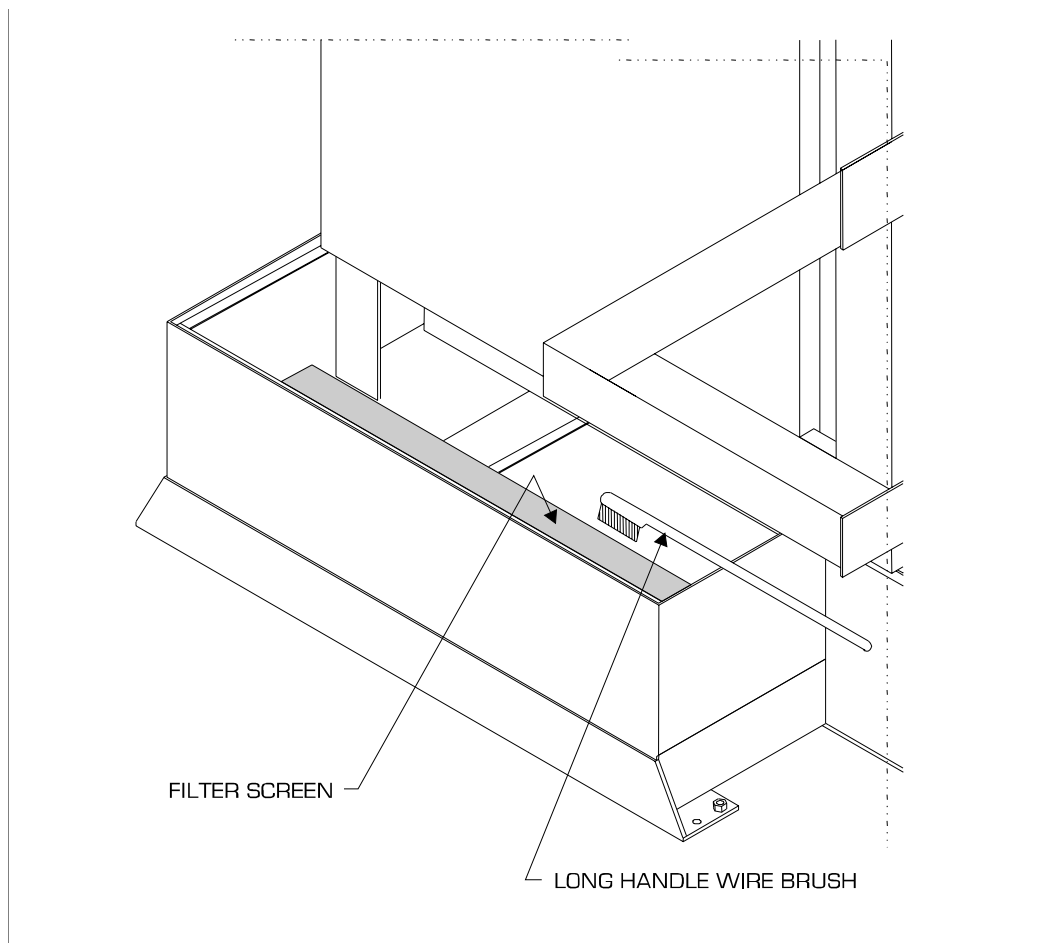

Fig. 5 - 2: Cleaning the Pump Intake Filter Box

2.1.2. PBM Swivel Joint (Grease)

Grease the PBM Swivel Joint with Lubriplate 1444. Refer to the following figure.

NOTE: It is *imperative* that the PBM swivel be greased every 8 hours of operation!

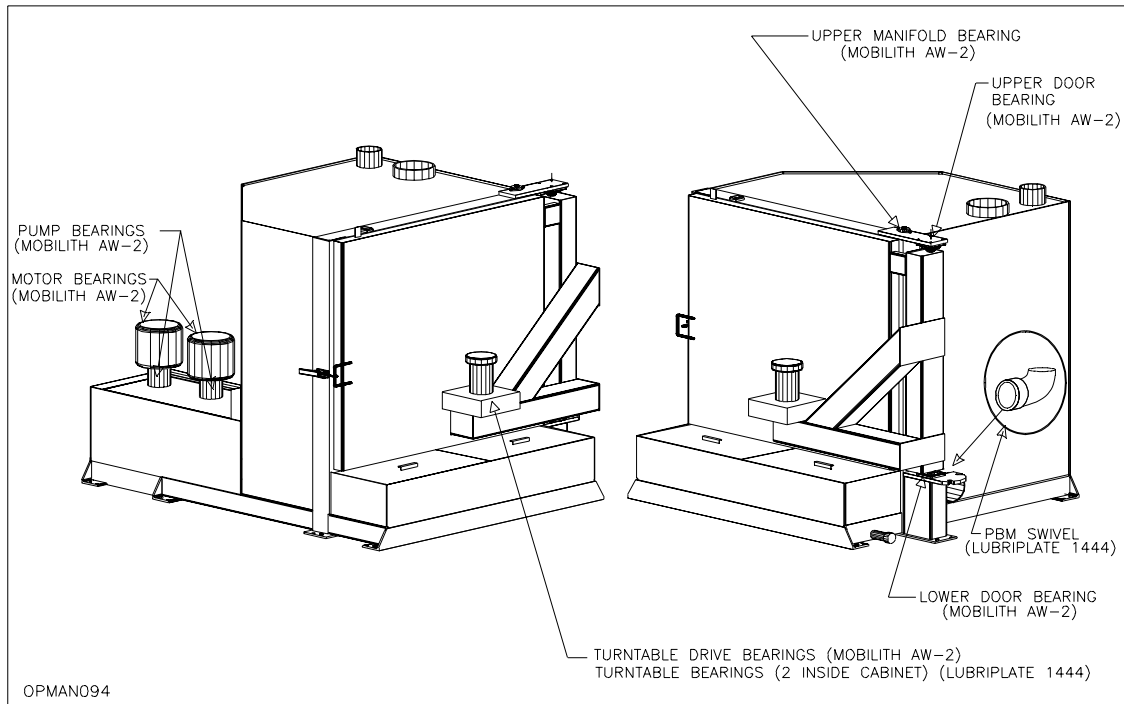

Fig. 5 - 3: Lubrication Chart

2.1.3. PBM Nozzles (Inspect/Monitor)

Inspect the PBM wash-and-rinse nozzles for clogging and alignment. The flat-spray nozzles are aligned with "punch" marks on the manifold to ensure an overall uniform coverage, which gives you the best cleaning results. When you check for clogging, be sure to check that all nozzles are correctly aligned, as indicated in the following figure.

Monitor the amperage draw at the main wash pump(s) to check for worn nozzles: A higher amperage draw than normal (check your baseline readings) indicates that nozzles may need to be replaced. Remember that a worn nozzle is not always visually apparent -- nozzle tips can look fine, but actually be quite worn. Since a worn tip can spray at up to 30% over capacity, amperage draw will be higher.

If nozzles need to be cleaned or replaced, follow this procedure:

WARNING! Do not stand or walk on the false floor inside the cabinet, or on the reservoir cover.

1. Turn the *main power supply OFF*.
2. Remove the nozzle with a 9/16-inch (14 mm) wrench.
3. Remove any debris.
4. Apply 6 –7 turns of teflon tape to the threads.
5. Re-install the old nozzle, or install a new one. Thread nozzle finger tight and snug up with wrench 1 to 1-1/2 turns. Observe alignment "punch" marks on the PBM, and align the "V" slot in the nozzle with the marks. Do not over tighten. Refer to the following figure.

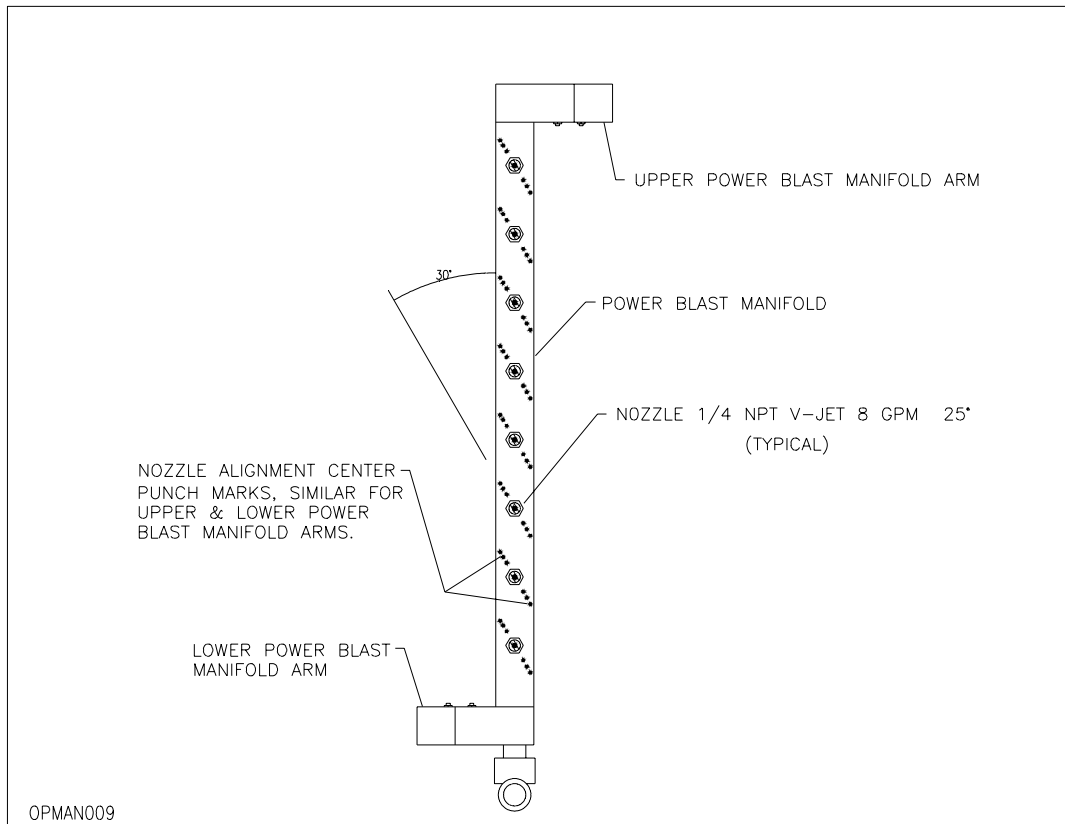

Fig. 5 - 4: Cleaning and Replacing the PBM Nozzles

2.1.4. PBM Swivel (Inspect/Adjust)

Inspect the PBM swivel to be sure it is rotating freely.

Follow this procedure:

1. Turn the *main power supply OFF*.
2. Disconnect the *PBM linkage* from the *PBM upper bearing/shaft*.
3. Open the washer cabinet *door*.
4. Push the *manifold* back and forth. *If* it does not move freely, *and if* you have been greasing the manifold regularly, you need to adjust the jam nut. The jam nut is located on the swivel at the bottom of the PBM manifold. The swivel assembly allows for take-up of the packing after it wears.
5. Swivels with *Jam Nuts* only: Adjust the *PBM swivel jam nut* so that it swings freely, but is as tight as possible in order to prevent leaking around the joint.

Follow this procedure:

- Remove the lock bar.
- Screw the nut clockwise to the next locking slot (until compression on the packing causes the nipple to rotate with a mild amount of torque).
- Re-install the lock bar.
- You may repeat this process until the packing has worn too badly to keep a tight seal.

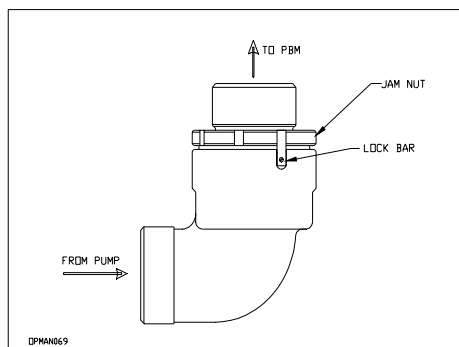
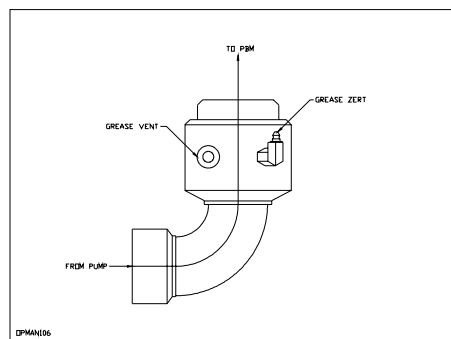

Fig. 5 - 5: Swivel Jam Nut



Non-adjustable swivel

2.1.5. Amperage Draw at Wash Pump(s) (Measure)

Measure and record the amp draw from the wash pump motor(s), using a clamp-on amp meter.

CAUTION! *Be sure that ONLY a qualified electrician performs this maintenance task!*

NOTE: Take the amperage measurement at the load side of the wash pump starter(s) on each power leg. If the washer is equipped with a duplex pump system, take amp readings separately on each wash pump motor, with both pumps running.

Compare amperage readings with the maximum amp load, which is calculated as follows:

On each pump motor, find the manufacturer's specification tag. The tag indicates two things: **(1)** Full-load amperage draw at your specified voltage; *and* **(2)** The service factor, which is either 1.15 or 1.25 times the full-load amperage, depending on motor size and incoming voltage.

Multiply the full-load draw (as indicated on the motor tag) by the service factor in order to calculate the maximum allowable amp load.

The actual amperage draw reading on each motor is to fall below the maximum calculated allowable amp load.

If the actual amperage draw reading exceeds the maximum calculated allowable amp load, this could indicate that nozzles are worn and need to be replaced, or that there are some other leaks in the system. Refer to section "PBM Nozzles" above, and to chapter "Troubleshooting/Wash Pump System."

2.1.6. Upper Manifold Bearing (Grease)

Grease the PBM upper manifold bearing with Mobilith AW2. Refer to Fig. 5-3.

2.1.7. Wash Pump and Pump Motor (Grease)

NOTE: 10 HP wash pumps have no bearing grease points.

NOTE: Use Mobilith AW2 to grease the pump and the pump motor.

CAUTION! *Overgreasing creates heat. Do NOT overgrease the pump or pump motor.*

CAUTION! *Too much lubricant is a major cause of premature motor failure. If you apply too much grease, it is eventually forced out of the bearing housing and begins dripping on the motor windings. The grease then attacks and destroys the insulation, resulting in early motor failure.*

CAUTION! *Use ONLY a manually operated grease gun. Do NOT use a power grease gun.*

To grease the pump, follow this procedure: (refer to the following figure)

1. Turn the *main power supply OFF*.
2. Remove the *plugs* opposite the *grease fittings* on both ends of the bearing frame.
3. Clean the *grease fittings*.
4. Use a *manually operated grease gun* on the fittings.

5. Add approximately *1 ounce (2.9 ml)* of fresh grease for each bearing (which is about *2-3 hand-pumps of grease* for each bearing).
6. Replace the *fittings and plugs*.
7. Turn the *main power supply ON*.

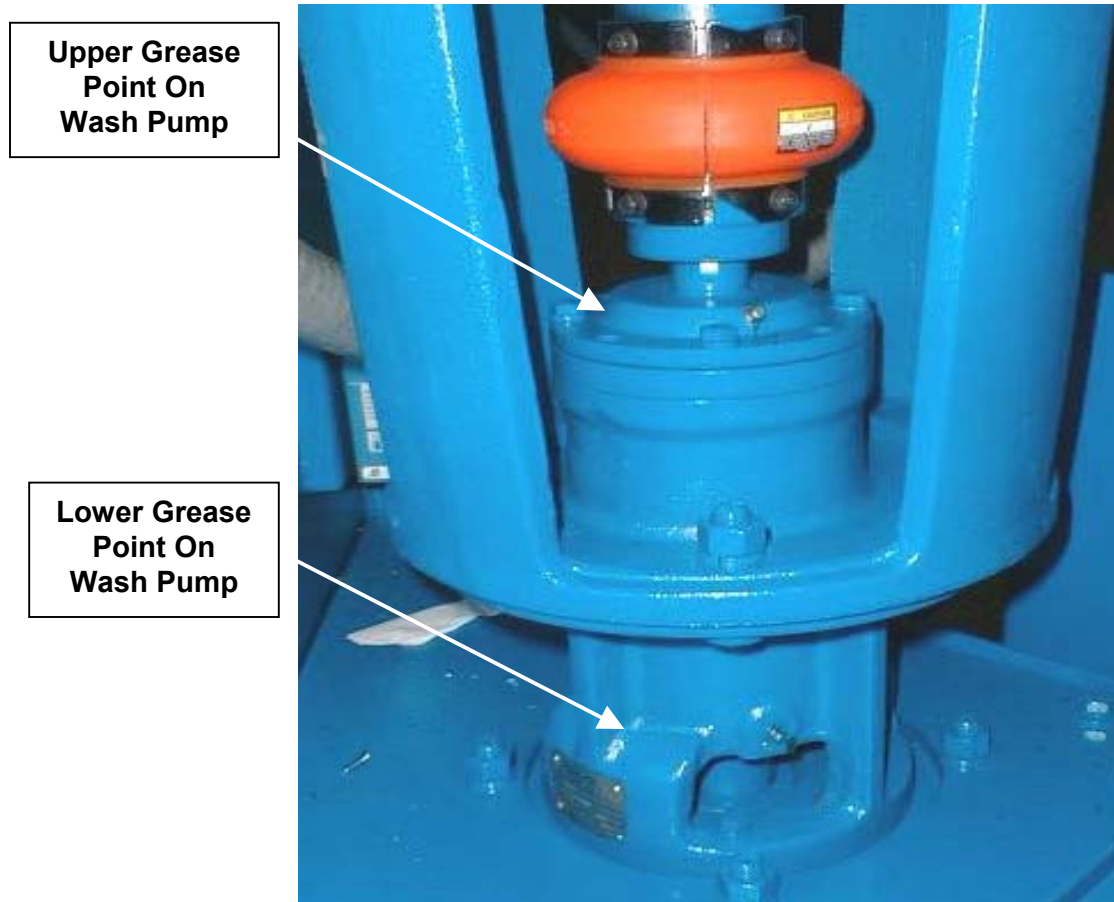

Fig. 5 - 6: Wash Pump and Pump Motor(s)

To grease the pump motor(s), follow this procedure: (refer to the previous figure)

1. Turn the *main power supply OFF*.
2. Clean the *grease fittings*.
3. Grease the wash pump motor point.
4. Use a *manually operated grease gun*.

5. Add approximately *1 ounce (2.9 ml) of fresh grease* (which is about *2-3 hand-pumps of grease*).
6. Turn the *main power supply ON*.

2.1.8. Wash Pump Couplings (Inspect)

Inspect the wash pump(s) couplings for the following:

- Wear
- Separation
- Misalignment

Refer to Fig. 5-6 as you inspect couplings for the following:

Wear	If couplings are worn, replace them.
Separation	If couplings are separated, loosen them and re-adjust their position.
Misalignment	If couplings are misaligned, they are also probably worn or separated. Loosen the couplings and re-adjust their position. Also, check the bolts for tightness.

2.2. Heating System

This section describes maintenance procedures for the following:

- Air intake - burner blower motor (clean)
 - Burner blower motor (oil)
-

2.2.1. Air Intake - Burner Blower Motor (Clean)

Clean the air intake on the burner blower motor (natural gas, L.P. gas, or fuel-oil fired burners only) with a compressed-air blower or a soft brush, in order to remove dust and dirt. Refer to the following figure.

2.2.2. Burner Blower Motor (Oil)

Oil the burner blower motor with a standard electric-motor oil, suitable for small electric motors. For example, 10W-50 SAE oil. Refer to the following figure.

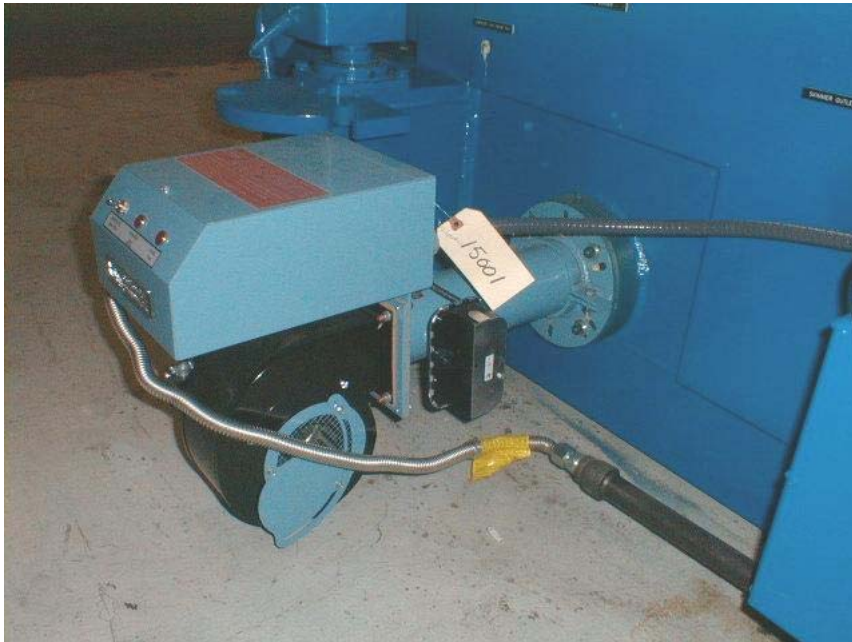

Fig. 5 - 7: Burner Blower Motor (380,000 BTU Burner Shown; Other Sizes Similar)

2.3. Water-Level Control System

This section describes maintenance procedures for the following:

- Float assembly (inspect/clean)
- Water solenoid valves (clean or replace)

2.3.1. Float Assembly (Inspect/Clean)

Inspect/Clean

Inspect the float assembly periodically. The single-ball float system normally requires little or no cleaning -- however, under some operating conditions, you may have to clean the operating rod and float ball.

Refer to the following figure to locate these parts:

- Check the *cam set screws* for tightness.
- Check the *float ball to rod connection* for tightness.
- Clean the *float ball*, if necessary.

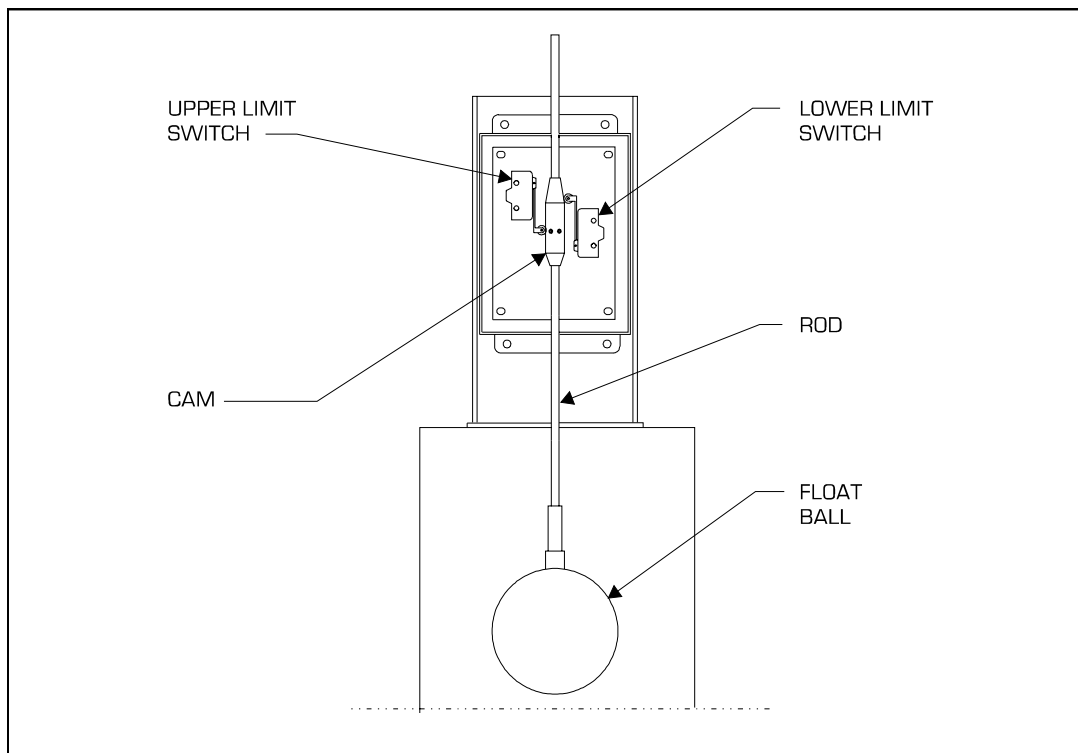

Fig. 5 - 8: Float Assembly

Making Adjustments (see chapter "Installation/Power-Up Procedure/Water-Level Control" for more information)

If the water level is more than 1/8" above or below the water-level indicator, follow this procedure:

1. Remove solution until the solution level is below the set-point.
2. Let the washer fill automatically and shut off.
3. *If the water level is more than 1/8" inch above or below the water-level indicator, you will need to adjust the cam on the float rod. Follow the steps below.*

Turn the power *OFF*.

Remove the float-control box cover.
4. Mark the current location of the cam on the float rod with a marker or a piece of tape before making any adjustments.

*If the water-level measurement you made is higher than the indicator, you will need to move the cam **up** the float rod by the difference between the indicator and the measured value*

*If the measurement is lower than the indicator, you will need to move the cam **down** the float rod by the difference between the indicator and the measured value.*

Measure the distance to the new position and mark it on the float rod.

Next, loosen the two set-screws on the cam with an Allen wrench.

Finally, slide the cam to the new location, and re-tighten **both** set-screws.
5. Turn power on to the washer and test the new level by allowing the washer to fill to the old set-point.

NOTE: It will be necessary to remove water from the washer if the new level is lower than the new set-point.

Verify that the set-point level is correct. If necessary, repeat the above steps until the set-point level is at the indicator, plus or minus 1/8" inch.
6. Replace the cover on the float box and tighten the four screws.

NOTE: If your washer has a rinse system, once operations have started water levels in the washer can be higher than the set-point water level. This happens whenever the washer automatically uses the rinse-bank for longer rinses.

To verify the correct set-point water level after operations have started, you must allow the washer to fill to the set-point. You can check this by observing the position of the float cam relative to the limit switches in the float box. (Refer to Fig. 1-3: Float-Level Mechanics) If the cam is higher than the set-point, you will have to remove solution from the washer and allow the washer to fill to the set-point to check set-point water level.

REMEMBER!! NEVER CHANGE THE POSITION OF THE LIMIT SWITCHES -- they are pre-set. For more information on the limit switches, refer to chapter "Overview."

2.3.2. Water Solenoid Valves (Clean or Replace)

Disassemble the water solenoid valves, and clean or replace the diaphragms with re-build kits.

Refer to your vendor-supplied cut sheet for instructions.

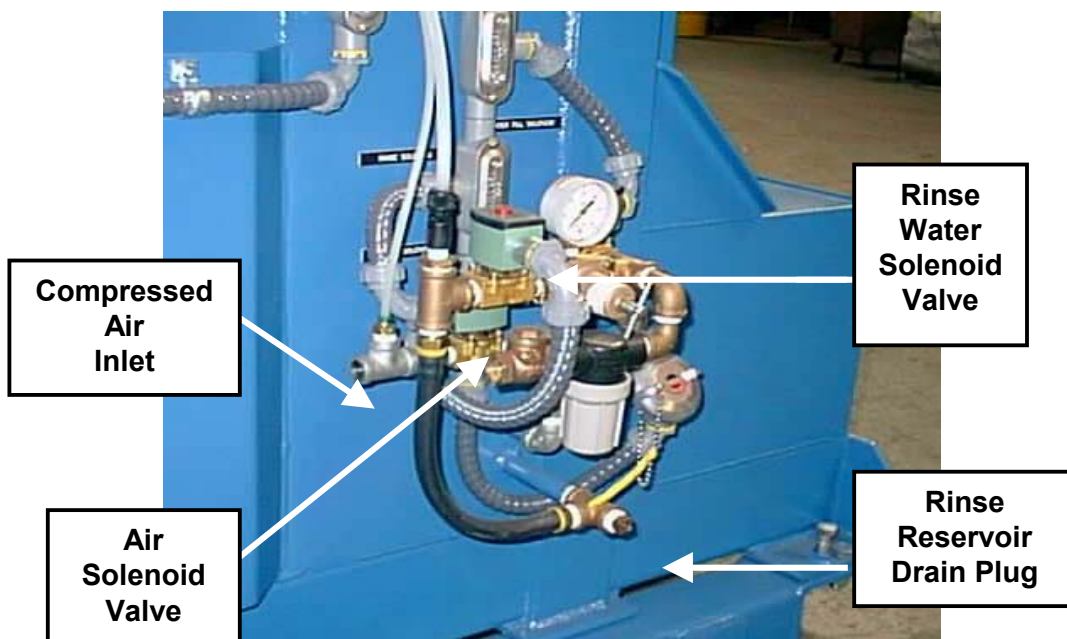

Fig. 5 - 9: Solenoid Valves

2.4. Turntable and Drive Assembly

This section describes maintenance procedures for the following:

- Turntable bearings (grease; Lubriplate 1444)
 - Turntable drive bearings (grease; Mobilith AW2)
 - Slip clutch/torque limiter (inspect)
 - Door bearings (grease; Mobilith AW2)
-

2.4.1. Turntable Bearings (Grease)

Grease the upper and lower turntable bearings with Lubriplate 1444. Refer to Fig. 5-3.

NOTE: It is *imperative* that the turntable bearings be greased every 8 hours of operation! (except Cyclone 30's and Tornado 40's)

Pump in enough grease at each lubrication interval to completely fill the bearing. The quantity required will depend on the bearing size and other wash parameters which you set. As a rule of thumb when using a hand grease gun, pump until the grease gun feels "stiff" and then add an additional 2 or 3 pumps/squirts or until grease is visible at the seals.

Cyclone 30's and Tornado 40's Turntable roller bearings only.

Cyclone 30's and Tornado 40's have extended life bearings that require lubrication every 1100 hours of operation.

To lubricate the turntable roller bearings proceed as follows.

Remove the turntable. Remove the rubber seal from the top of the turntable spindle head. Locate zerk fitting and re-lubricate bearing with Lubriplate 1444 until grease is visible around upper bearing nut. Replace seal and re-install turntable.

2.4.2. Turntable Drive Bearings (Grease)

Grease the turntable drive bearings with Mobilith AW2. Refer to Fig. 5-3.

2.4.3. Slip Clutch/Torque Limiter (Inspect)

The slip clutch is factory pre-set to 45 foot-pounds (6.2 kg-m), which is 5 foot-pounds (.7 kg-m) below the allowable motor torque. Slight slippage during washing is common and normal.

Inspect the slip clutch/torque limiter during operation of the washer. Under normal operation you may see some slippage -- the sprocket jack shaft starts and stops while the motor shaft turns constantly. However, if the clutch slips constantly and nothing is jamming the turntable, you need to adjust the clutch.

You will need to remove the motor-drive assembly to adjust the clutch. Clamp the assembly on its side in a vise, or clamp it to a secure work surface, so that the sprocket can be rotated.

Follow this procedure: (refer to the following figure)

1. Devise a means of restraining the sprocket. (*For example:* Weld a nut to the bottom sprocket support plate. Use a nut that is appropriate for your torque wrench.)
2. Use a torque wrench with 50 foot-pound (6.9 kg-m) capability.
3. Loosen the set screws on the large hexagon torque-adjusting nut.
4. Restrain the torque-limiter threaded shaft at the motor. Use the torque wrench to turn the sprocket until the clutch slips.
5. Tighten or loosen the large hexagon torque-adjusting nut to adjust the clutch setting.
6. Set the max torque to 45 foot-pounds (6.2 kg-m) to slip the clutch.
7. Tighten the set screws on the large hexagon torque-adjusting nut.

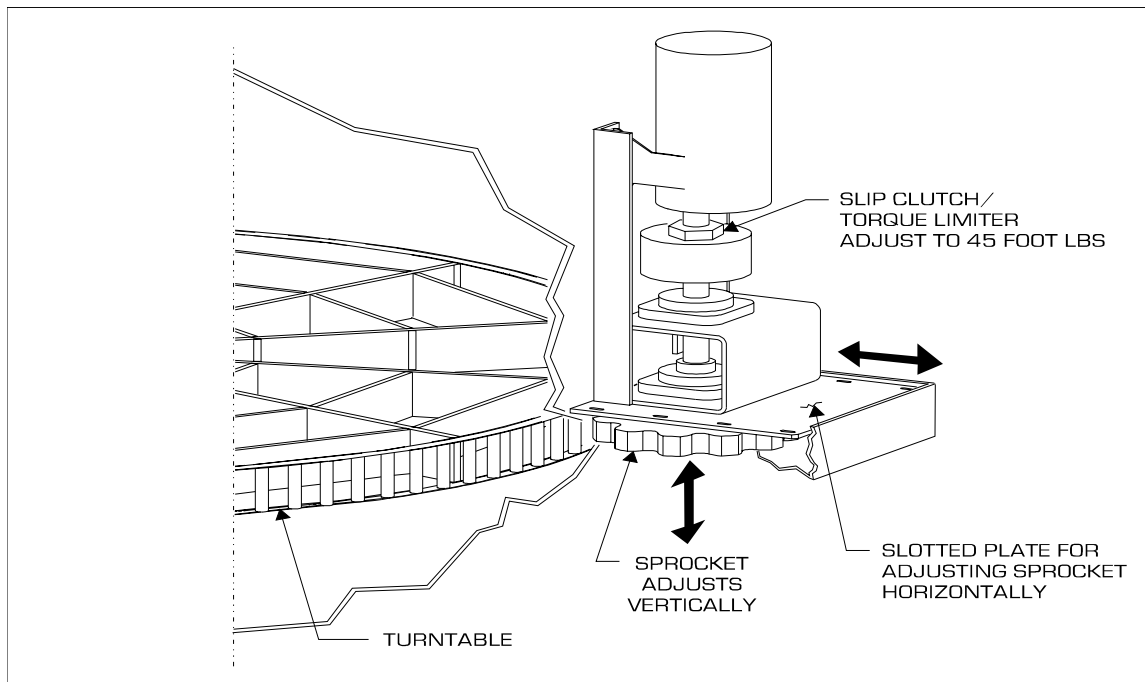

Fig. 5 - 10: Turntable Drive and Turntable: Slip Clutch/Torque Limiter

2.4.4. Door Bearings (Grease)

Grease the upper and lower door hinge bearings with Mobilith AW2. Refer to Fig. 5-3.

2.5. Auto Steam Exhaust (ASE) Assembly

ASE Blower Motors are lubricated for life. No additional lubrication is required.

2.6. Chemical Concentration

There are two methods to test chemical concentration and maintain the proper chemical charge:

1. Titration Test

Titration is the estimation of the strength of a compound by measuring the amount of another compound of known strength that is required to produce an observable reaction.

Almost all titration kits supplied with cleaning compounds use phenolphthalein (indicator P) as a reactant, and an acid (hydrochloric or phosphoric) as a neutralizer. The indicator P turns red or pink or blue when added to a sample of the solution. By counting the drops of acid it takes to turn the solution back to its original color, you can arrive at a good *estimate* of the chemical concentration.

Titration Testing Guidelines:

- Perform a titration test weekly.
- Contact your chemical supplier for test kits.
- Use a kit designed specifically for your chemical.
- Follow test kit instructions.
- Add chemical based on the results of the test.

When you perform a titration test, do the following:

1. Allow the sample solution to cool to room temperature.
2. Filter the cooled solution to remove impurities.
3. Hold the titration reagents vertical when you add drops to the sample. This ensures "size accuracy" of the drops coming out of the reagent bottles.

4. Use clean laboratory flasks, vials, and bottles for all titrations. Dirty tools can produce invalid test results.
5. After testing the sample, pour it back into the washer.

For improved testing accuracy:

1. Prepare a "control" sample using fresh city water and chemical to the desired concentration.
2. Titrate this "control" sample.
3. Compare titrations of the wash solution to the results of the "control" in order to determine if you need to add chemical.

2. Conductivity Test (optional)

If your washer is equipped with optional conductivity-test instruments, refer to chapter "*Options*," section "*Chemical Concentration Controller*," for information on performing a conductivity test.

2.7. Voltage

This section describes maintenance procedures for the following:

- Voltage at power distribution block (measure)
-

2.7.1. Voltage at Power Distribution Block (Measure)

Measure and record the incoming voltage to the washer *with wash pump(s) running*.

CAUTION! Be sure that ONLY a qualified electrician performs this maintenance task!

NOTE: Take the measurements inside the electrical control panel, at the power distribution block. If the voltage drop is more than 10% below the voltage required for operation of the washer, call MART.

3. Sludge Monitoring and Clean-Out

This section describes maintenance procedures for the following:

- Sludge (monitor and clean out)
- Heat exchanger and suction tube (clean)
- Heating element(s) (clean - electric only)

Generally, when you clean out sludge, clean the heat exchanger and suction tube as well as the heating elements (if you have electric heat), since all require that the washer be emptied.

NOTE: Maintenance of heating elements may need to be done more often than sludge clean-out, or cleaning of the heat exchanger and suction tube.

WARNING! Do not stand or walk on the false floor inside the cabinet, or on the reservoir cover.

3.1. Sludge Monitoring

To monitor and measure sludge accumulation on the bottom of the reservoir, follow this procedure:

1. Remove the front-reservoir cover.
2. In the front-right corner of the reservoir, push a long stick vertically down to the reservoir floor.
3. Remove the stick.
4. Observe the sludge mark on the stick.
5. If 4 inches (10 cm) of sludge is indicated, clean out the washer.

3.2. Sludge Clean-Out and Heat Exchanger/ Suction Tube (Clean)

Clean the heat exchanger and suction tube when you clean out sludge, since both maintenance procedures require that the washer be emptied. If your washer uses

electric heat, clean the heating elements as well (see the following section for instructions).

Follow this procedure:

1. Turn the *main power supply OFF*.
2. Allow the *solution to cool* to room temperature.
3. Remove the front *reservoir cover*.
4. Use oil-absorbent pads or newspaper to *soak up floating oil and scum*.
5. Discard the pads by an *approved waste-disposal method*.
6. Pump the **solution** into *holding barrels*.

CAUTION! Do NOT pump out the SLUDGE!

7. Move the door position lock to allow the washer cabinet *door* to open to a 180° angle from the cabinet frame.
8. Remove the *false floor*.
9. Remove *sludge* from the bottom of the reservoir.
10. Dispose of the *sludge* by an approved waste-disposal method.
11. Clean under the *heat exchanger* with a stiff brush.
12. Flush out the *suction tube*.
13. Replace the *false floor*.
14. Position the door at a 90° angle from the cabinet frame.
15. Pump *solution* from the *holding barrels* back into the *reservoir*.

16. Replace the *front reservoir cover*.
17. Turn the *main power supply ON*.

NOTE: The power washer controls will automatically fill the reservoir with the correct amount of water.

18. Perform a *chemical-titration test*, and add chemical as indicated by the test results.
19. Allow solution to heat up to operating temperature before running a wash cycle.

3.3. Heating Elements (Clean - electric only)

This procedure applies to electrically heated power washers *only*.

NOTE: Maintenance of heating elements may need to be done more often than sludge clean-out, or cleaning of the heat exchanger and suction tube.

Follow this procedure:

WARNING! Turn the main power supply **OFF** and allow solution to cool to room temperature before cleaning heating elements.

1. Remove the front *reservoir cover*.
2. Pump the **solution** into holding barrels.

NOTE: Empty solution to a level just below the heating elements.

3. Position the door at a 180° angle from the cabinet frame.
4. Remove the *false floor*.
5. Wire-brush or pressure wash the *heating element(s)*. Refer to the following figure.
6. After cleaning the heating element(s), pump solution back into the reservoir.

7. Re-install the false floor.
8. Turn the *main power supply ON*.
9. Allow solution to heat up to operating temperature before running a wash cycle.

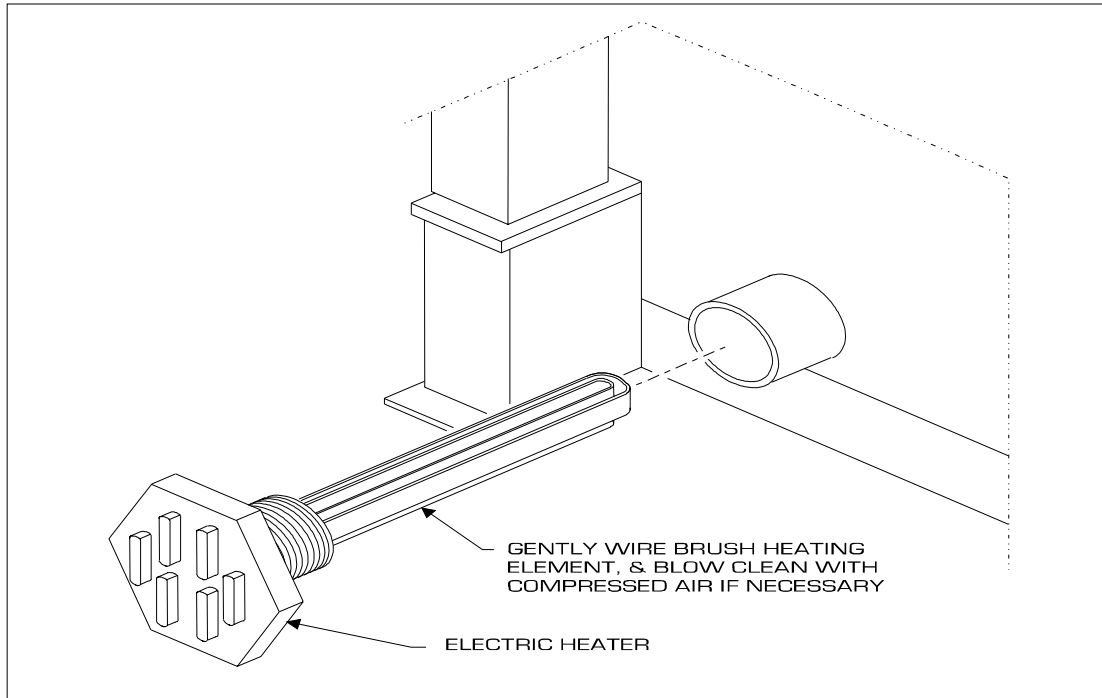

Fig. 5 - 11: Cleaning the Heating Elements

4. Maintenance of Options

For instructions on performing maintenance of options you have purchased from MART, refer to chapter "*Options.*"