

# MART EQ-1 Wastewater Processing System

## Operating Manual



**MART EQ-1 MODEL 250  
Wastewater Processor**



**The MART Corporation**

2450 Adie Road • St. Louis, MO 63043 USA  
314-567-7222 • 1-800-543-MART • FAX 314-567-6551  
e-mail [themart@martwash.com](mailto:themart@martwash.com) • [www.martwash.com](http://www.martwash.com)

P/N 54649

This manual is an unpublished, copyrighted work by The MART Corporation.

The information and drawings in this Manual are the property of The MART Corporation and shall not be reproduced or copied or used in whole or in part in other media without written permission.

Copyright 1998,2000,2003,2005 by The MART Corporation. All rights reserved.

NOTE: The information contained in this Manual is subject to change at any time without notice. Some information contained in this Manual may also be inaccurate due to undocumented changes in the equipment or operating system after this version of the Manual was completed. The information contained in this version of the Manual supersedes all previous versions. No liability is assumed with respect to the information contained herein.

# **MART EQ-1**

## **Wastewater Processing System**

Version 10.0

April 2005

**The MART Corporation  
2450 Adie Road  
Maryland Heights, MO 63043-9978 USA  
Phone: 1-800-543-MART (1-800-543-6278)  
Missouri Direct: (314) 567-7222  
Fax: (314) 567-6551  
E-Mail: [the\\_mart@martwash.com](mailto:the_mart@martwash.com)  
Website: [www.martwash.com](http://www.martwash.com)**

**NOTE: The MART EQ-1 Wastewater Processing System has been tested and approved for industrial use by the U.S. EPA-LTV and for Military use by the MEEP Test Program**

# Table of Contents

<b>Important Safety Instructions and Warnings .....</b>	<b>4-5</b>
<b>1 Overview .....</b>	<b>6</b>
Purpose.....	6
Materials and Components.....	6-7
Theory of Operation.....	7-8
Processor Inspection.....	8
<b>2 Installation.....</b>	<b>9</b>
Safety and Precautions.....	9-10
<b>3 Basic Operation.....</b>	<b>11</b>
Control Box.....	11
Operating Instructions.....	11-15
<b>4 Advanced Operation.....</b>	<b>16</b>
Chemical Management.....	16
pH Adjustment (manual or auto).....	16
Final Polishing System (optional).....	17- 18
<b>5 Maintenance.....</b>	<b>19</b>
Service Schedule.....	19
<b>6 Troubleshooting.....</b>	<b>20</b>

# Important Safety Instructions and Warnings

*The following important safety instructions and warnings apply to installing, operating, maintaining, and troubleshooting the MART EQ-1 Processor. They also apply to repairing the MART EQ-1 Processor, or working with the system in any way.*

## SAVE THESE SAFETY INSTRUCTIONS!!!

### **GENERAL SAFETY INSTRUCTIONS FOR OPERATING THIS PRODUCT:**

- 1. Read all safety and operating instructions and procedures before installing, operating, maintaining, troubleshooting, or repairing the Processor ... or working with the system in any way.*
- 2. KNOW HOW to operate the MART EQ-1 Processor. Be familiar with all its controls.*
- 3. Stay alert at all times, and watch what you are doing.*
- 4. Do NOT operate the MART EQ-1 Processor if you are tired, if you have ingested alcohol, or if you have taken any drugs, including prescription medications.*
- 5. Keep the operating area clear of people.*
- 6. Do NOT overreach or stand on an unstable support when operating or servicing the MART EQ-1 Processor. Keep a good footing and balance at all times.*
- 7. Follow the instructions in this Manual for Installation, Operation, Maintenance, Troubleshooting and Repair.*

**CAUTION!** *The MART EQ-1 Processor is designed to be electrically connected to a 3 prong grounded receptacle only. The ampacity of the receptacle must be at least 15 amp.*

**CAUTION!** *If the use of an extension cord is required, use only an approved 3-wire grounding-type cord of adequate amperage.*

**CAUTION!** *Do not process waste solution above 125 F (52 C).*

**CAUTION!** *Wear the appropriate protective clothing and use extreme caution when handling acids or any other highly charged chemical.*

**CAUTION!** The MART EQ-1 Processor uses specially formulated chemical compounds known by Magic Dust, its trade name. DO NOT use unapproved products. Use of chemical compounds not recommended by MART will void your warranty, can result in incomplete waste processing, can be dangerous, and can result in possible personal injury.

**WARNING!** Verify that the people installing the MART EQ-1 Processor are qualified and trained for the work.

**WARNING!** Install the MART EQ-1 Processor to conform to all local code requirements.

**WARNING!** The MART EQ-1 Processor is designed to be installed inside a building, not outside.

**WARNING!** DO NOT EVER get inside the MART EQ-1 Processor while in operation or while the machine is connected to the electrical power. This could result in severe injury or death.

**CAUTION!** **WHEN HANDLING, LOADING AND UNLOADING ENCAPSULATED WASTE OR LIQUID** -- Always wear gauntlet-type thermally protected and water-repellent protective gloves, protective eyewear, and a full body apron that is thermally protected and water-repellent.

**DANGER!** Improper connection of the equipment-grounding connector can create a risk of electrocution.

**CAUTION!** The MART EQ-1 Processor must be unplugged before performing any maintenance procedures.

**WARNING!** To reduce the risk of electrocution, keep all connections dry and off the ground. Do not touch electrical connections or the electrical plug with wet hands.

# Chapter 1 Overview

## Purpose

This Chapter introduces you to the MART EQ-1 Wastewater Processor System. Read this Chapter thoroughly before attempting to install, operate, or maintain the MART EQ-1 Processor system.

The photographs below show the major features and components of the EQ-1 Processor.

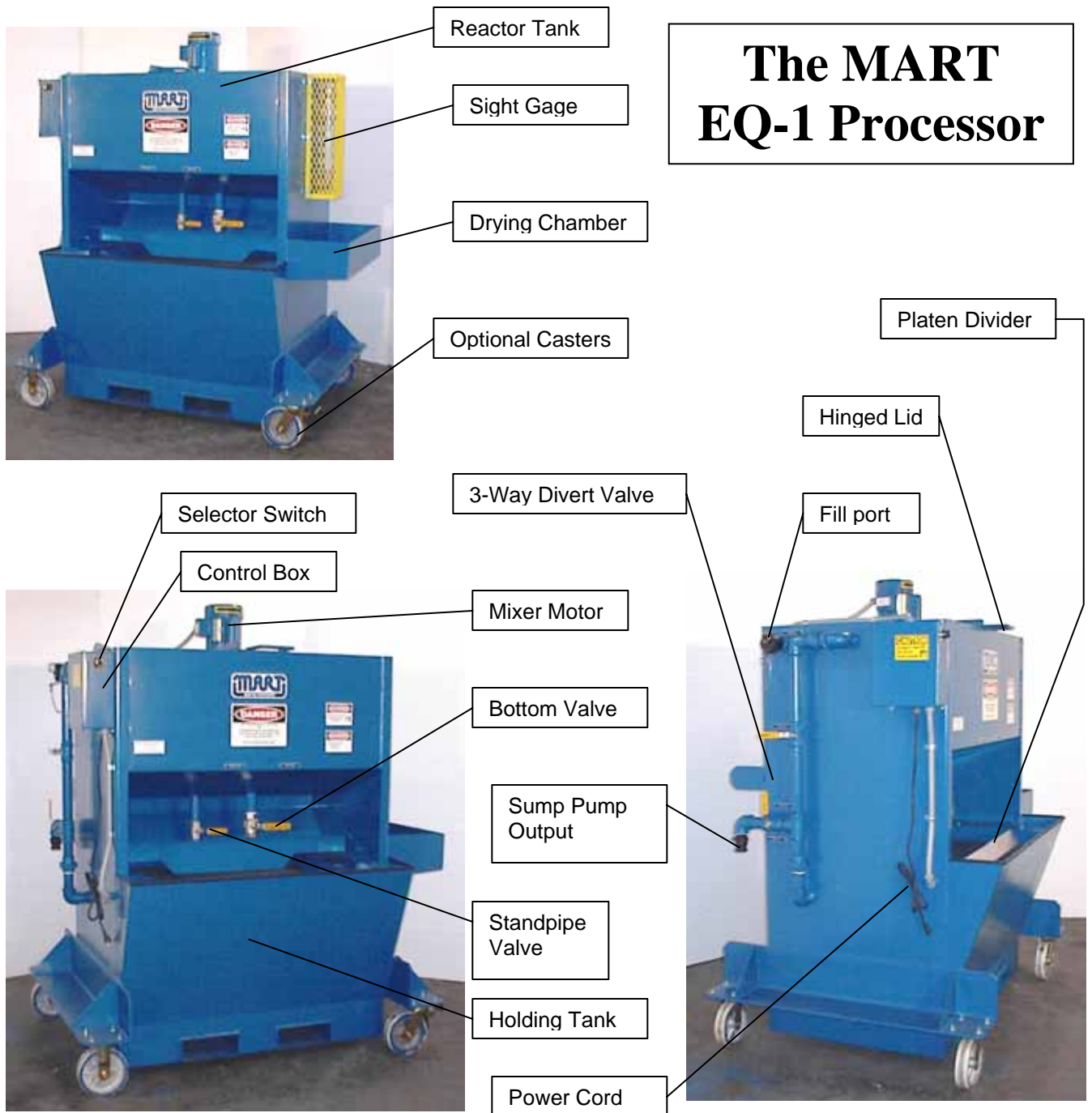

The MART EQ-1 Processor is designed to be plugged into a 3-prong grounded electrical outlet of at least 15 amp capability. The power requirement is 120 VAC, 15 amps at 60Hz single phase.

### **Equipment specifications:**

Mixing Motor: 3/4 hp @ 3450 rpm

Holding Tank Sump Pump for clean solution transfer: 30 gal/min

The MART EQ-1 Processor, depending on the model, has a total solution capacity of 125, 250, 375 or 500 gallons. The Solution Reactor Tank has a capacity of 125 gallons. The Processor is portable and fitted with quick disconnects to service multiple systems and a variety of waste streams. Forklift pockets are provided for easy transportation. Optionally, the Processor may be anchored to the floor and hard piped to a Power Washer or other aqueous washing system.

### **Ground-Fault Circuit Interrupter Protection**

The MART EQ-1 Processor is provided with a ground fault circuit interrupter (GFCI) built into the power cord. This device provides additional protection from the risk of electric shock. Should replacement become necessary, use only identical replacement parts that include GFCI protection.

### **Theory of Operation**

The MART EQ-1 Wastewater Treatment System is an inventive technology that recovers Alkaline cleaner and water for reuse. The processor chemically separates and clarifies spent wash solution and encapsulates the waste for disposal. The chemical compound used in the MART encapsulating process is a non-hazardous product called by its trade name, Magic Dust.

The Upper Reservoir is the Reactor Tank. Wastewater solution is pumped into the Reactor Tank where Magic Dust is added and the batch is mixed. Unlike conventional wastewater flocculating systems that require multiple steps and the addition of several chemicals, one charge of Magic Dust and a few minutes of mixing completes the MART EQ-1 separating and encapsulating process. In some cases, a pH adjustment is required before processing a batch of wastewater (this information is included in your Wastewater Treatability Report furnished by MART).

During the mixing of the agglomerate, complex reactions and micro-encapsulation occurs. Molecules with adsorbed oil, metallic ions, and charged contaminants are attracted to the Magic Dust to form a mass. This process is referred to as flocculation and the encapsulated waste is called floc. The water is clarified and retains about 75% of its active chemical. A Sight Tube is provided on far right side of the Reactor Tank to allow the operator to see when the separation/encapsulation process is complete.

After microencapsulation, the flocculated waste is filtered through a disposable media paper to collect the waste for disposal. Two valves control the solution flow. The Standpipe Valve controls the flow of the clarified solution and light floc. The Bottom Valve controls the flow of heavy floc.

The Filter Paper containing encapsulated waste is rolled up like a burrito and placed in the Drying Tray located on the right side of the EQ-1 Processor. After several days the rolled waste hardens into a hard solid form almost like cement for handling and disposal.

The clarified solution is collected in the Holding Tank located at the bottom of the EQ-1 Processor. A Submersible Pump in the Holding Tank transfers clarified solution to the upper Reactor Tank for thorough rinsing, to the Power Washer reservoir for reuse or to another optional filtering system such as the MART Final Polishing System for sewer disposal.

## **EQ-1 Inspection**

When you receive your new MART EQ-1 Wastewater Treatment system, inspect it for shipping damage. Note any damage on the bill of lading and report the damage to the freight company and to MART.

- **Inspect the entire unit for dents and scrapes.**
- **Inspect the Mixing Motor and Sight Tube for damage.**
- **Inspect the control panel, wiring, pipes and valves for breaks or cracks.**
- **Note that a supply of filter media paper and Magic Dust is included with the shipment.**



## **Chapter 2   INSTALLATION**

**Before you begin the installation, read and follow the recommended safety-precaution instructions.**

To move the MART EQ-1 Processor, use a forklift, the optional locking casters, or another suitable method that works under the base frame. Set the Processor in place and level it.

The Processor must be plugged into a properly grounded electrical outlet of at least 15-amp capacity. If an extension cord is required, use only a 3-wire extension cord of at least 15-amp capacity.

### **Grounding Instructions:**

This equipment must be grounded. If the Processor should malfunction or break down, grounding provides a path of least resistance for electric current to reduce the risk of electric shock. This machine is equipped with a cord having an equipment-grounding conductor, a ground fault circuit interrupter (GFCI) and a grounding plug. The plug must be plugged into an appropriate electrical outlet that is properly installed and grounded in accordance with all codes and ordinances, and good practice.

### **Extension Cords:**

Use only a 3-wire extension cord that has a 3-prong grounding-type plug and a 3-pole cord connector that accepts the plug from the Processor. Use only an extension cord that is designed for outdoor use. These extension cords are identified by a marking "Acceptable for use with outdoor appliances; store indoors while not in use." Use only an extension cord having an electrical rating not less than the rating of the Processor.

Do not use a damaged extension cord. Examine the extension cord before using and replace if damaged. Do not abuse extension cord and do not yank on the cord to disconnect. Keep cord away from heat and sharp edges. Always disconnect the extension cord from the receptacle before disconnecting the Processor from the extension cord.

### **Mixer Rotation:**

Check the rotation of the propeller to be certain of clockwise rotation as viewed when looking down from motor end to the propeller. If rotation is incorrect, change the wiring according to the motor nameplate.

## Chapter 3 BASIC OPERATIONS

THE MART EQ-1 PROCESSOR UNIT HAS THE FOLLOWING ELECTRICAL CONTROLS:

<b>Control Panel Selector Switch</b>	Center position is "OFF." Left position turns Mixer Motor "ON". Right position turns Sump Pump "ON".
--	--

THE FOLLOWING VALVES ARE LOCATED ON THE FRONT OF THE EQ-1 PROCESSOR, UNDERNEATH THE REACTOR TANK:

<b>Bottom Valve</b>	This valve is located below and on the right side of the Reactor Tank. The valve drains encapsulated waste from the bottom of Reactor tank.
---------------------	---

<b>Standpipe Valve</b>	This valve is located below and on the left side of the Reactor Tank. The valve drains clarified liquid from the mid point of the Reactor tank.
------------------------	---

NOTE: The Standpipe, located inside the Reactor Tank, can be cut to adjust the drain depth of flocculated material. The adjustment will enable clarified solution to flow more quickly and speed wastewater processing.

THE FOLLOWING VALVE IS LOCATED ON THE LEFT SIDE OF THE EQ-1:

<b>Sump Pump Diverter Valve</b>	This 3-way valve diverts clean solution flow from the Holding Tank Sump Pump. With the handle in its vertical position, clean solution can be pumped to the Reactor Tank Rinse Manifold. With the handle in the horizontal position, clean solution is pumped out of the discharge port to your clean solution storage (holding) tank or back into your MART Power Washer.
-------------------------------------	--

## OPERATING INSTRUCTIONS

Before operating the EQ-1 Processor for the first time, MART recommends a thorough review of the Chapter 1, Overview of Important Safety Instructions.

***WARNING: Be sure individuals operating this equipment are Qualified and have the proper training. Operators must wear the proper safety equipment (i.e. gloves, apron, face shield).***

### Mixer Operation

The EQ-1 is equipped with a powered mixer. It is designed to operate continuously under normal conditions.

***CAUTION: Do not run the Mixer unless the Reactor Tank is full. This will prevent excessive splashing and Mixer vibration. Operating the Mixer without a full Tank can lead to mechanical damage.***

Maintenance: Check the Mixer mounting hardware and Drive Shaft Set Screws for tightness on a weekly basis.

### EQ-1 Process Operating Instructions

Follow these instructions to process a batch of wastewater in your EQ-1.

1. The basic processing steps are:
2. Fill the Reactor Tank with wastewater.
3. Add Magic Dust and mix the wastewater.
4. Observe that floc develops.
5. Filter the flocculated solution through the filter paper.
6. Wrap the waste.
7. Rinse the Reactor Tank.
8. Pump the clean solution back to the Power Washer.

These steps are described in detail below:

***CAUTION: Your wastewater must be cooled to below 125 degrees F before processing in the EQ-1. Higher temperatures are dangerous to work with as you can be scalded or burned and they can damage the EQ-1.***

1. Load the Filter Paper. Place the Filter Paper roll on the spindle at the rear of EQ-1 Processor. Feed the Filter Paper through the rear slot and pull the paper over the expanded steel Platen until it extends about 6 inches in front of the Platen divider.
2. Close both reactor tank valves. The valve marked Standpipe and the valve marked Bottom Valve must be closed.
3. Connect your transfer pump hose to the inlet port on the left upper side of the EQ-1. Transfer wastewater into the Reactor Tank until the level reaches the Fill Line Marker next to the Sight Tube (approximately 125 gallons).

**NOTE:** *Transfer Pump is NOT supplied with the EQ-1 System . A separate transfer pump, available as an option, must be used to fill the Reactor Tank. The Sump Pump in the Holding Tank is for clean solution only.*

4. The wastewater should be thoroughly mixed prior to processing. If the wastewater has been undisturbed in the Reactor Tank for more than 30 minutes, agitate the solution for about 3 minutes or until the mixing sequence times out.

**WARNING!** *Magic Dust is hygroscopic (moisture attracting). Magic Dust should be kept in a cool and dry area. Wetted chemical may present a slipping hazard. Even a small Magic Dust spill should be cleaned up immediately.*

**WARNING!** *Inhalation of chemical, or frequent contact with bare skin, presents health and safety hazards. An individual working with Magic Dust must wear personal protection equipment such as chemical resistant gloves, safety goggles, protective clothing, and a dust mask.*

**NOTE!** *Magic Dust exposed to moisture may form lumps that are difficult to dissolve. Check Magic Dust before adding to wastewater to make certain that no lumps are present.*

**NOTE!** *Keeps mix time to a minimum to prevent chewing up accumulated floc! Over-mixing can result in "Pin Floc" that can seep through filter paper and contaminate the processed solution. "Pin Floc" can also coat filter paper, making filtration difficult.*

**NOTE!** *Never discharge solution or waste unless the Filter Paper is in place and fully covers Platen. Adjust flow through the valves so that the wastewater does NOT spill over the edges of the Filter Paper.*

**NOTE!** The mixer will pulse on and off (adjustable to 0-1 min.) for a selected period of time (adjustable to 0-10 min.). The timers are factory set. The pulse timer is set at 15 seconds and the reaction timer at 3 minutes. These times may be adjusted as necessary for the specific application. See "Chapter 4" for "Adjusting Mix Time."

5. Processing the Batch:

1. Turn the Control Panel Selector Switch to the Mixer position. This starts the automatic mixing sequence.
2. Open the hinged lid on top of the Reactor Tank and, while Mixer is running, slowly pour in the recommended dosage of Magic Dust. Close lid.
3. After Mixer pulsing sequence stops (about 3 minutes), allow a few minutes for the floc to develop. Observe this process in the Sight Tube. The time required is dependent on the concentration of the contaminants in the waste stream. You can watch the process evolve in the Sight Tube and know when flocculation is complete.

6. The floc in the sight tube is observable in one of the following three conditions:
  1. SETTLED FLOC (Follow Procedure "A"): The floc is heavy and settles to the bottom.
  2. FLOATING FLOC (Follow Procedure "B"): The floc is light and buoyant, and floats.
  3. COMBINATION FLOC (Follow Procedure "A" of "B"): The floc is a combination of both floating and settled material.



**Settled floc in the Site Glass**

7. **FILTRATION:** The procedure to filter the reacted solution depends on the condition of the floc. By choosing the correct procedure you minimize the amount of time it takes to filter the solution. With either procedure let the clear portion of the flocculated solution flow out of the reactor tank first. The clear solution is easy to filter and quickly flows through the filter paper as shown in the picture.

When the floc settles drain the clear solution from above by using the standpipe valve. This leaves the settled floc in the bottom of the reactor tank. Follow "Filter Procedure A" for this type of settled or combination floc.

Procedure "B" is followed when the floc floats to the surface. In this case, the clear solution is first drained from the bottom of the reactor tank. Opening the bottom valve allows the solution to quickly flow through the filter paper. Follow "Filter Procedure B" for solutions that only have floating floc.



"FILTER PROCEDURE A": For Solutions with fully settled or combination (partially settled) floc.

- 1) Open the Standpipe Valve slowly and allow the clarified solution to drain through the filter paper and into the Holding Tank.
- 2) Next, open the Bottom Valve slowly and drain approximately 1 to 1-½ inches of solution on to the filter paper. Close the Bottom Valve. Allow enough time for the water to drain through the filter paper. Wrap-up the filter paper and floc as describe in step 8.
- 3) Repeat steps 1 and 2 until the reactor tank is emptied.

"FILTER PROCEDURE B": For Solutions with primarily floating floc.

- 1) Keep the Standpipe Valve closed. Open the Bottom Valve slowly and allow the clarified solution to drain through the filter paper and into the Holding Tank. Close the Bottom Valve when the floc begins discharging.
- 2) Open the Bottom Valve again and slowly and drain approximately 1 to 1-½ inches of solution. Close the Bottom Valve. Allow time for the water to drain through the filter paper. Wrap the filter paper and floc as describe in step 8.
- 3) Repeat steps 1 and 2 until the reactor tank is emptied.

## 8. HANDLING ENCAPSULATED WASTE:

- 1) As the clear solution drains through the filter paper without the encapsulated waste discharge, slowly pull the Filter Paper forward over the Platen Divider.



**Draining encapsulated waste onto the filter paper**

This exposes fresh filter paper and allows you to begin wrapping up the waste in the filter paper.



**Rolling a "Burrito"**



- 2) Roll the encapsulated waste in the filter paper in a manner similar to making a “burrito.”
- 3) When a sufficiently large “burrito” [about 6 inches in diameter] has formed you must cut the filter paper and start another wrap. Pull about 6 inches of encapsulated waste-coated Filter Paper over the Platen Divider. Cut the Filter Paper along the Platen Divider with a box cutter or knife.
- 4) Finish wrapping the burrito and move it to the drying chamber



**Wrapped “Burrito” in the drying chamber**

- 5) Continue wrapping the floc material and pulling the filter paper forward until all of the encapsulated waste is wrapped up and placed into the drying chamber.
9. REACTOR TANK RINSING: After the filtration of the flocculated solution is complete you must rinse the Reactor Tank as follows:
- 1) Rotate the Sump Pump Diverter Valve vertically to the rinse position (handle vertical).
  - 2) Open the Standpipe Valve and Open the Bottom Valve.



- 3) Turn the selector switch to the pump position.
  - 4) Allow the pump to discharge through the rinse manifold and through the filter paper for 20 to 30 seconds.
10. After rinsing the Reactor Tank, follow “Step 9” above to remove the dirty filter paper.
  11. **EMPTY THE HOLDING TANK:** To return the clean solution to the washer, rotate the Sump Pump Diverter Valve horizontally to the drain position (handle horizontal). Connect a hose to sump pump discharge port on the EQ-1 and put the other end into Power Washer or clean solution storage tank. Turn the selector switch to the pump position and start pump to transfer clarified solution to the solution storage or back to the Power Washer. The pump will shut down automatically when the Holding Tank Float Switch closes.
  12. Turn the control panel selector switch to the off position.
  13. Remove the cap on the top of the Sight Tube and clean the tube with the brush provided. Replace the cap when finished.
  14. The Processor is now ready for the next batch of wastewater to be recycled.

***NOTE! Completely remove the Reactor Tank cover and inspect for cleanliness and nozzle wear at least once every 3 months. Clean the system as needed. Clean or replace nozzles as required.***

## Chapter 4 ADVANCED OPERATION

### Chemical Management

Your MART EQ-1 Wastewater Treatment System uses Magic Dust, a non-hazardous chemical, to process your wastewater. A site-specific Magic Dust formulation was developed according to your unique application and requirements, and your local water conditions.

You have been assigned a formula number and a dosage rate for your wastewater. Keep this information accessible to reorder Magic Dust. Report any problems or changed operating or processing conditions to MART Tech Services.

Magic Dust formulations have an effective processing pH range of about 5 to 11. If your pH is beyond this range, pH adjustment may be necessary. Refer to your Treatability Report for details.

Changes in your chemical or cleaning process may warrant additional testing of your wastewater to ensure that the Magic Dust formula developed for you remains effective.

EQ-1 processing recovers as much as 90% of the unused wash chemicals from cleaning operations. As a result it may be necessary to add fresh cleaning chemical to your solution. Titrate your wash water to determine the proper amount of chemical to add to bring your wash solution concentration back to normal operating conditions.

### Adjusting pH

**CAUTION!** *Wear the appropriate protective clothing and use extreme caution when handling acids or any other highly charged chemical.*

In some cases an adjustment in pH will be necessary to maximize the effectiveness of your Magic Dust compound.

#### Adjusting Mix Time

In some cases an adjustment in mixing process time will be necessary to maximize the efficacy of wastewater processing. Insufficient mixing will result in a reduction of floc and will waste the Magic Dust. Too much mixing will chew up the floc which will have the consistency of mud. The reaction also requires residence time for the floc to develop. Adjusting the mix time and the pulse rates can improve the formation of large stable floc which filters more easily and faster.

The Mixer Pulse Timer is factory set to pulse on for 15 seconds and off for 15 seconds. The pause between mixing allows the floc to grow. It is not normally necessary to adjust this Timer.

The Mix Timer is factory set at 3 minutes. This time may need to be increased for the specific wastewater conditions. Check the Sight Tube during mixing to observe the maximize floc size. If the floc is not fully developed in the site tube, increase this Timer.

**CAUTION!** *Keeps mix time to a minimum to prevent chewing up accumulated floc! Over mixing can result in pin floc that can seep through filter paper and contaminate the processed solution.*

To adjust the Timers, refer to the following photograph and do the following:

- Disconnect the power to the EQ-1 Processor.
- Remove the Control Panel cover.
- Adjust the appropriate timer to the desired duration.
- Timer Number. 1 controls the total reaction (mix) time from 0-10 minutes.
- Timer Number. 2 controls the pulse time from 0-60 seconds.
- After adjustments are made, replace the cover and reconnect the power. Do not operate the EQ-1 Processor without the cover in place.

**CAUTION!** *Do not set Timer No. 2 below 5 seconds! Excessive pulsing of the mixer motor may damage the motor or the motor controls.*

## MART EQ-1 Control Panel

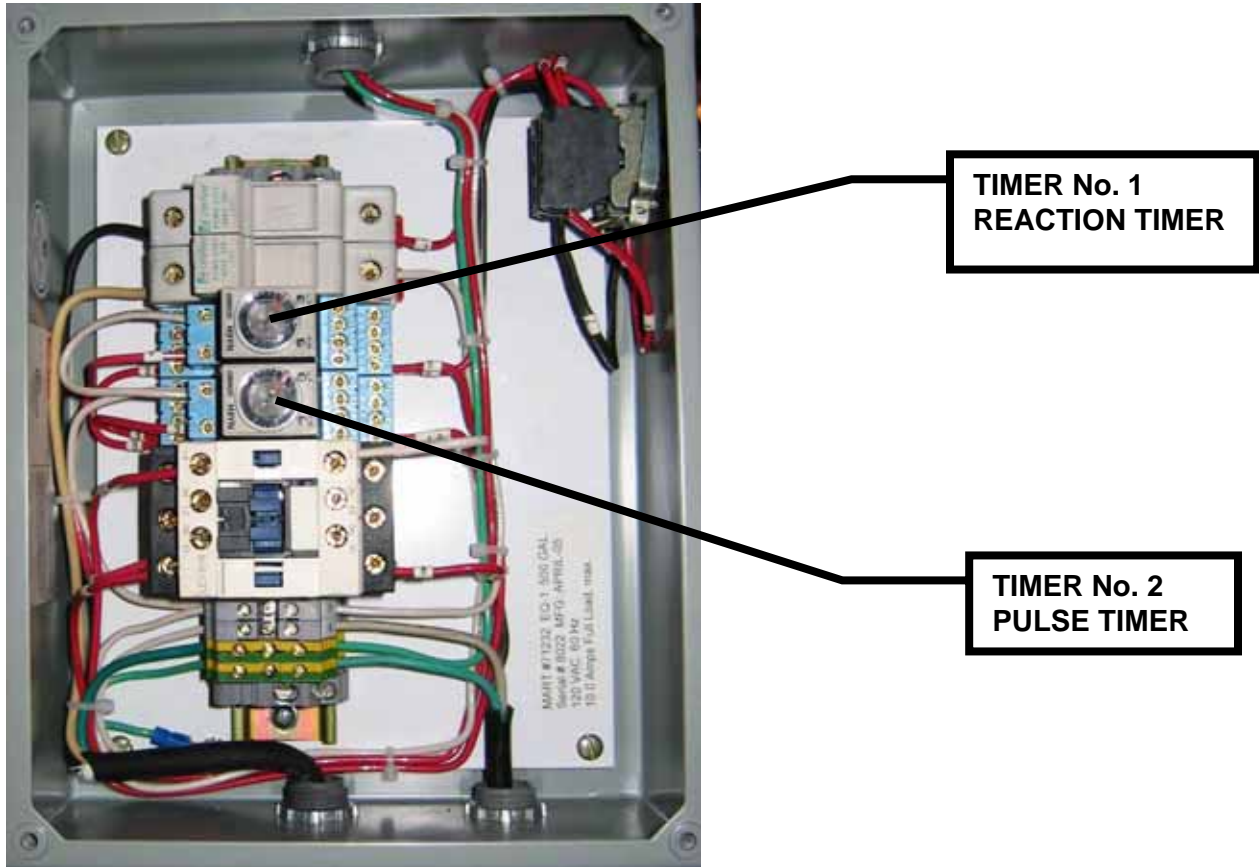

## Overloaded Filter Paper

In some cases under developed floc causes the Filter Paper to overload with solids so that draining takes an excessive amount of time. This makes pulling the filter paper forward difficult without tearing it. One way to prevent tearing of the paper and speed up the filtration process is to scoop excess encapsulated waste from on top of the filter paper into a bucket. Be careful not to tear the paper. A flat bottom scoop works best for this operation.

# MART EQ-1 Processor Options



**MART EQ-1 Model 250 Wastewater Processor With Optional Locking Casters.** Heavy duty casters mounted to lower reservoir for easy movement between work sites. Brake and lowered center of gravity maximize safety and minimize tip over.

**MART EQ-1 Model 250 With Optional Final Polishing (Ion Exchange) System.** Pre-Filter with Depth wound Cartridge and Ion Exchange Chamber with 0.5 cubic feet Resin. Filters heavy metals at discharge rates up to 90 gal/hr. Effluent may be suitable for sewer discharge. Includes Magnetically Coupled Pump, refillable Resin Chamber, and Flow Control Gauge.

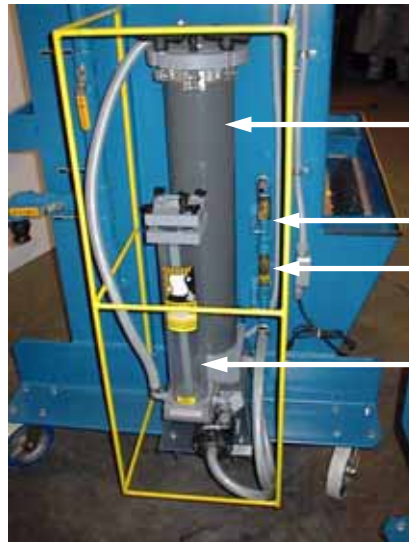

- Re-Fillable Resin Chamber:  
0.5 cu ft capacity
- Flow Control valve
- Flow Meter
- Acrylic Pre-Filter Chamber:  
15 micron filter



**MART EQ-1 Transfer Pump & Cart Assembly.** Two (2) inch diameter Flap Valve Air Operated Diaphragm Pump mounted on cart with swivel casters and brakes. Has 15 ft Inlet Hose and 15 ft Outlet Hose with 1.5" male and female Quick Disconnects to mate with the MART EQ-1 Processor. Pump has adjustable flow rate up to 140 GPM.



**The MART Corporation**  
 2450 Adie Road • St. Louis, MO 63043 USA  
 314-567-7222 • 1-800-543-MART • FAX 314-567-6551  
 e-mail themart@martwash.com web site: www.martwash.com

## **(Optional)**

### **FINAL POLISHING ION EXCHANGE SYSTEM (FPS)**

The Final Polishing System is a basic ion exchange system that employs positively charged Polystyrene resin bead medium to facilitate the ionic exchange.

The ion exchange system should only be used as directed by MART to maximize the life of the resin.

#### **The Equipment:**

##### **Unit specifications:**

Flow rate=72 GPH for optimum removal efficiency.

Maximum flow rate=480 GPH

Max. PSI =13

1/6 HP motor (115/230V)

##### **Acrylic pre-filter chamber (located on the front of the FPS unit):**

- a) 3 inch diameter
- b) 25 inch tall
- c) One 20 inch 15 micron filter cartridge

##### **Refillable resin chamber located in the rear of the FPS unit:**

- d) CPVC chamber and housing.
- e) 0.5 cubic feet capacity
- f) PVC shell with three 250 micron polypropylene strainers to prevent resin from migrating into the filtered solution.
- g) Magnetic Coupled Pump
- h) 10 foot PVC hose for discharge
- i) Resin Bag and resin

#### **Operating Instructions:**

Follow instructions for EQ-1 Basic Operation.

After processing with the MART EQ-1 system, turn Power Switch to the "ON" position to operate the Final Polishing System.

Clarified solution is pumped into the Pre-Filter to remove oil and grease and other contaminants that may hinder the effectiveness of the resin beads. The solution should enter at a rate less than 72 GPH (1.2 GPM). The flow rate is controlled a Flow Control Valve and can be measured with the Flow Meter (range is .5 to 4 GPM). Next, the

solution is sent through the Resin Chamber where the heavy metals are removed by ion exchange (sodium ions replace the metal ions in solution).

The metal ions are captured on the beads. The resin has approximately a 1 lb per .5 cu/ft capacity. In normal operation the resin should last about 2-3 months. There is no way to visually determine if the resin is spent. Two methods of determining when the resin needs replacement: Method 1: Use a conductivity/resistivity meter to measure the conductivity of the influent and effluent solution. The incoming solution from the EQ-1 Lower Reservoir will have high conductivity due to the remaining metal ions in the solution, the effluent should have a lower conductivity due to the removal of these ions. Method 2: Purchase a kit to determine the level of ion concentration.

For replacement resin and filter media contact MART Tech Services.

After exiting the Resin Chamber the final effluent may be ready for discharge.

**Important Note: Prior to discharge into local POTW, The MART Corporation strongly suggests that solution be sampled to ensure discharge limits are met. Treated solution should be stored in the interim.**

## Chapter 5 MAINTENANCE

### Preventative Maintenance

The MART Corporation recommends that a preventative maintenance schedule be established for processing the wastewater. More frequent processing shortens the treatment time and the reduces the dosage rate of the Magic Dust. A good starting point to determine frequency is to treat the solution after one week of use. If this processing proves successful, try treating after two weeks and continue extending the time between treatments to determine the best treatment frequency. Note that, if the reservoir is allowed to become too saturated with contaminants, the treatment process will become difficult or even impossible.

### Service Schedule

The only servicing to the MART EQ-1 Processor is a thorough washdown after each use. The Processor has a built-in rinse system to facilitate the wash down procedure. It is important to periodically remove the secured cover on the upper Reactor Tank for inspection and cleaning as necessary.

Empty and rinse the Processor after each use. Never leave solution in the Processor for extended periods. Aggressive chemicals can damage the finish and corrode the tanks. Clean the Sight Tube with the Sight Tube Brush provided with the EQ-1 Processing System.



**Site tube & Brush**

For Maintenance and Servicing of the EQ-1 Sump Pump and Mixer, refer to the vendor-supplied operating manuals or speak with a MART Service Technician at 1-800-567-MART (6278).



## Chapter 6 TROUBLESHOOTING

Problem	Solution
Mixer will not start.	<ol style="list-style-type: none"> <li>1. Check electrical connections.</li> <li>2. Unplug unit from electrical receptacle and check power cord GFI unit. Press "RESET" button.</li> <li>3. Check Fuses for continuity.</li> <li>4. Check timer settings.</li> </ol>
Sump Pump will not start.	<ol style="list-style-type: none"> <li>1. Check electrical connections.</li> <li>2. Verify that solution is in Holding Tank.</li> <li>3. Check that Sump Pump Float Switch is not sticking.</li> </ol>
Filter paper clogging.	Pull forward and roll up used portion of Filter Paper so fresh clean paper is on the Platen.
Filter paper tears.	Too much waste material on filter paper will cause paper to tear from the weight of water and waste. Reverse the Platen so that bottom side faces upward. Reposition the Filter Paper to extend beyond the Platen on all sides.
No floc, or very little floc, or pin floc.	<ol style="list-style-type: none"> <li>1. Verify that the specified Magic Dust compound is being used.</li> <li>2. Verify that correct amount of Magic Dust is being used.</li> <li>3. Add more Magic Dust.</li> <li>4. Shorten Mix time. A long mix time may chew up the floc.</li> <li>5. Verify that processing instructions in Manual are being followed.</li> </ol>
Mixer Pump vibrates while running.	<ol style="list-style-type: none"> <li>1. Unplug electrical connection. Process wastewater to empty Reactor Tank. Remove top cover. Inspect Propeller Blades and remove any dried waste from Blades.</li> <li>2. Rotate by hand to inspect motor shaft for straightness.</li> </ol>

For technical assistance please contact:

**MART Tech Services**

2450 Adie Road, St. Louis MO 63043

Phone: 1-800-543-MART (314-543-6278)

1-314-567-7222 in Missouri

FAX: 1-314-567-6318

Web: [www.martwash.com](http://www.martwash.com)

[www.marttechservices.com](http://www.marttechservices.com)

Email: [themart@martwash.com](mailto:themart@martwash.com)

Filter Paper

Platen divider



**375 Gallon EQ-1 with Casters**

Diverter Valve